

СОДЕРЖАНИЕ

Серия мотор-редукторов К

Общие сведения	3
Устройство конического редуктора	4
Варианты исполнения	5
Условное обозначение	6
Количество масла, заливаемого в конические редукторы типа К (КА)	7
Рекомендуемые типы масел для различных условий эксплуатации	7
Вес конических редукторов типа К (КА)	7
Подбор мотор-редуктора	8
Монтажное положение	10
Таблица номинальных значений	11
Номинальные значения основных параметров	13
Габаритно-присоединительные размеры	40

Каталог конических мотор-редукторов

Редуктор является элементом привода общего назначения и предназначен для увеличения крутящего момента и уменьшения частоты вращения различных машин и механизмов.

Конические мотор-редукторы серии К отличаются компактным исполнением, малошумностью работы, удобством компоновки в различных плоскостях.

Характерные свойства конических редукторов К:

•12 типоразмеров редукторов мощностью 0,12-200кВт (37,47,57,67,77,87,97,107,127,157,167,187).

•диапазон передаточных чисел 5,36 – 179,86;

•максимальный выходной момент – 50 кНм;

•допустимая радиальная нагрузка – 190 000 Н;

•корпус редукторов типа К изготавливается из чугуна;

•зубчатые колеса изготавливаются из стали, проходят термическую и финишную обработку (твёрдость зуба HRC60, толщина прочного слоя — более 0,5мм).

Все редукторы поставляются заполненные смазкой в количестве достаточном для установки в монтажном положении М1.

В качестве смазки используется:

•трансмиссионное минеральное масло (ISO класс вязкости 220, температурный диапазон использования масла от -10°С до +40°С).

Данные каталога по мощности и вращающему моменту, предоставленные в каталоге, относятся к монтажной позиции М1, при которой входная ступень редуктора не находится полностью ниже уровня масла. Подразумевается, что мотор-редукторы имеют стандартные характеристики, заполнены стандартным смазочным материалом и эксплуатируются в нормальных условиях.

Приведенные значения частоты вращения выходного вала мотор-редукторов являются ориентировочными.

Номинальную частоту вращения выходного вала можно рассчитать самостоятельно по номинальной частоте вращения электродвигателя и передаточному числу редуктора. Необходимо учитывать, что реальная частота вращения выходного вала зависит непосредственно от нагрузки на двигатель и параметров электросети.

УСТРОЙСТВО КОНИЧЕСКОГО РЕДУКТОРА

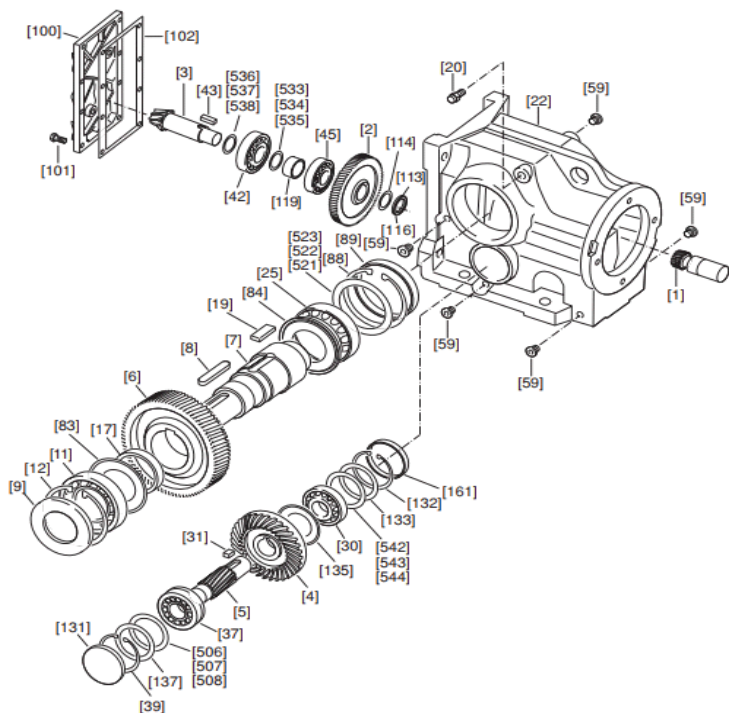

[1] Малая шестерня	[26] Подшипник качения	[102] Уплотнение	[522] Пригоночная шайба
[2] Колесо	[36] Подшипник качения	[116] Шлицевая гайка	[523] Пригоночная шайба
[6] Вал-шестерня	[31] Призматическая шпонка	[141] Стопорная шайба	[533] Пригоночная шайба
[4] Колесо	[37] Подшипник качения	[116] Резьбовой фиксатор	[534] Пригоночная шайба
[5] Вал-шестерня	[39] Стопорное кольцо	[116] Распорная втулка	[535] Пригоночная шайба
[6] Колесо	[42] Подшипник качения	[131] Заглушка	[536] Пригоночная шайба
[7] Выходной вал	[43] Призматическая шпонка	[132] Стопорное кольцо	[537] Пригоночная шайба
[8] Призматическая шпонка	[45] Подшипник качения	[133] Упорная шайба	[538] Пригоночная шайба
[9] Манжета для радиального уплотнения	[59] Резьбовая пробка	[135] Уплотнительная шайба	[542] Пригоночная шайба
[11] Подшипник качения	[83] Уплотнительная шайба	[137] Упорная шайба	[543] Пригоночная шайба
[12] Стопорное кольцо	[84] Уплотнительная шайба	[161] Заглушка	[544] Пригоночная шайба
[17] Распорная втулка	[88] Стопорное кольцо	[506] Пригоночная шайба	
[19] Призматическая шпонка	[89] Заглушка	[507] Пригоночная шайба	
[20] Воздушный клапан	[100] Крышка редуктора	[508] Пригоночная шайба	
[22] Корпус редуктора	[101] Болт с шестигранной головкой	[521] Пригоночная шайба	

КОНИЧЕСКИЕ МОТОР-РЕДУКТОРЫ ВЫПУСКАЮТСЯ В СЛЕДУЮЩИХ ИСПОЛНЕНИЯХ:

К...

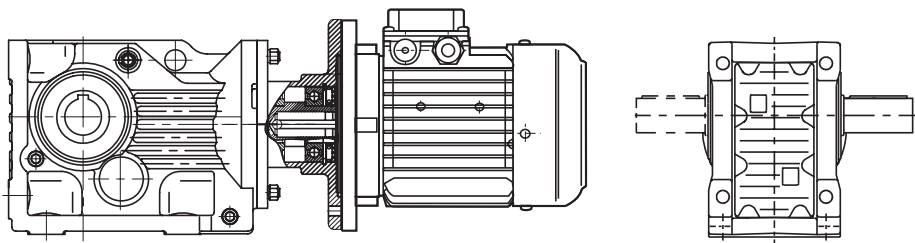

Конический мотор-редуктор на лапах

КА...В

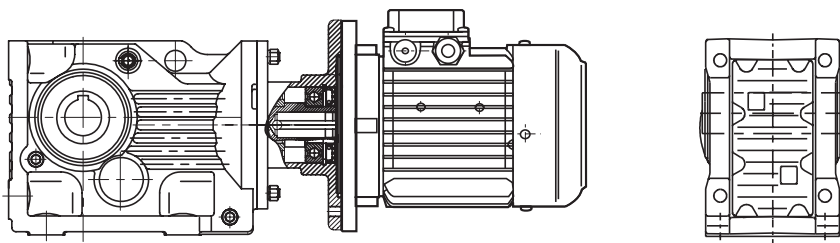

Конический мотор-редуктор на лапах с полым валом

КА...

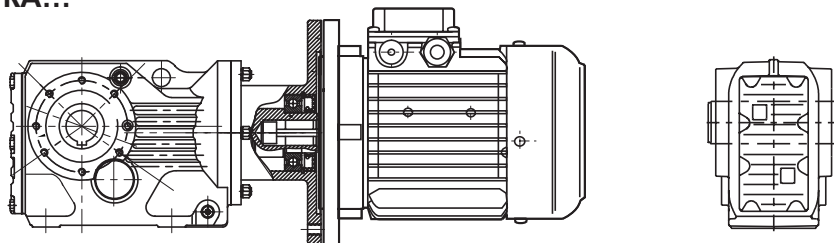

Конический мотор-редуктор с полым валом без лап

ПРИМЕР УСЛОВНОГО ОБОЗНАЧЕНИЯ РЕДУКТОРА И МОТОР-РЕДУКТОРА

Условное обозначение редукторной части конического редуктора типа К (КА)



Условное обозначение конического мотор-редуктора типа К (КА)

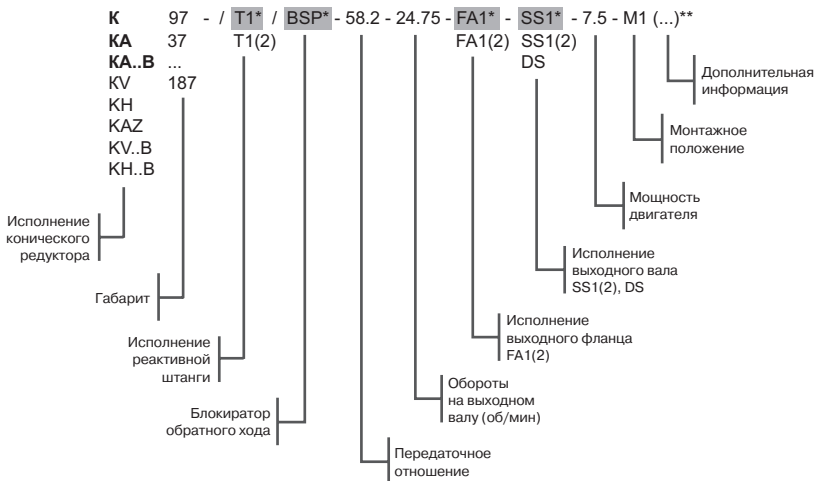

* При отсутствии данного модуля или детали в условном обозначении ничего не указывается

**Дополнительной информацией является нестандартное исполнение двигателя и фланца:

- двигатель с одним и двумя тормозами (ЕТ, ЕТ2ЕТ2)
- двигатель с двойными малозумными тормозами (ЕТ2ЕТ2 М)
- соединение редуктора с двигателем через малый фланец (В14)
- двигатель во взрывозащищенном исполнении (ВЗИ)
- нестандартное положение клеммной коробки (КК..)
- низкий сервис-фактор мотор-редуктора (f.s.=0.1-0.8)

Пример КА97- 44.32-21.2-2.2-M1 (100L6 ET12ET12M IM2082) f.s.=0.9

Таблица 1 - Количество масла, заливаемого в конические редукторы типа К (КА)

Редуктор	Количество масла в литрах					
	M1	M2	M3	M4	M5	M6
К..37	0.50	1.00	1.00	1.25	0.95	0.95
К..47	0.80	1.30	1.50	2.00	1.60	1.60
К..57	1.10	2.20	2.20	2.80	2.30	2.10
К..67	1.10	2.40	2.60	3.45	2.60	2.60
К..77	2.20	4.10	4.40	5.8	4.20	4.40
К..87	3.70	8.0	8.7	10.9	8.0	8.0
К..97	7.0	14.0	15.7	20.0	15.7	15.5
К..107	10.0	21.0	25.5	33.5	24.0	24.0
К..127	21.0	41.5	44.0	54.0	40.0	41.0
К..157	31.0	62.0	65.0	90.0	58.0	62.0
К..167	33.0	95.0	105.0	123.0	85.0	84.0
К..187	53.0	152.0	167.0	200	143.0	143.0

По умолчанию конические редукторы типа К(КА) поставляются заправленные маслом в объеме, соответствующем монтажному положению M1. Рекомендуемые типы масел для различных условий эксплуатации указаны в Таблице 2.

Таблица 2 - Рекомендуемые типы масел для различных условий эксплуатации

Тип масла		Синтетическое	Минеральное
Марка	Раб. темп	- 25 °С - 50 °С	- 5 °С - 40 °С
		ISO	VG 320
	AGIP	TELIUM	BLASIA 460
	SHELL	OMALA 320	OMALA 160
	ESSO	S220	SPARTAN EP460
	MOBIL	MOBIL GEAR 320	MOBIL GEAR 634
	CASTROL	AL PHASYN PG320	AL PHA MAX 460
	BP	ENERGOL SG-XP320	ENERGOL SG-XP460

Таблица 3 - Вес конических редукторов типа К (КА)

Габарит	K37 KA37	K47 KA47	K57 KA57	K67 KA67	K77 KA77	K87 KA87	K97 KA97	K107 KA107	K127 KA127	K157 KA157	K167	K187
Вес, кг	25 24	31 30	37 36	43 40	75 68	110 99	170 150	315 285	475 450	790 750	1190	1770

ПОДБОР МОТОР-РЕДУКТОРА

Данные, необходимые для подбора мотор-редуктора:

n_{2min} - Минимальная частота вращения выходного вала [об/мин]

n_{2max} - Максимальная частота вращения выходного вала [об/мин]

P при n_{2min} - Выходная мощность при минимальной частоте вращения выходного вала [кВт]

P при n_{2max} - Выходная мощность при максимальной частоте вращения выходного вала [кВт]

M при n_{2min} - Вращающий момент на выходном валу при минимальной частоте вращения [Нм]

M при n_{2max} - Вращающий момент на выходном валу при максимальной частоте вращения [Нм]

Fg - Внешняя радиальная нагрузка на выходной вал

Предполагает приложение усилия посередине вала. Иначе определите точное положение точки приложения усилия, указав угол приложения усилия и направление вращения вала для проверочного расчета. [Н]

Fa - Осевая нагрузка (растяжение и сжатие) на выходной вал [Н]

Монтажная позиция

IP.. - Необходимая степень защиты

T - Температура окружающей среды [°C]

Режим работы и относительная продолжительность включения, или укажите точный цикл нагрузки

Z - Количество включений, или укажите точный цикл нагрузки [вкл/ч]

f - Частота электросети [Гц]

Для рационального расчета параметров мотор-редуктора необходимо знать данные приводимого механизма (масса, частота вращения и т. д.). По этим данным определяются необходимые значения мощности, вращающего момента и частоты вращения.

КПД редуктора в большей степени зависит от трения в зубчатом зацеплении и в подшипниках. Важно учитывать тот факт, что КПД редуктора во время запуска всегда ниже, чем при номинальной частоте вращения.

КПД цилиндрических редукторов в зависимости от числа ступеней находится в пределах от 94% (3-ступенчатый) и до 98% (1-ступенчатый).

Выходной крутящий момент M

Крутящий момент M определяется требуемой нагрузкой редуктора. Его можно вычислить как усилие F, действующее на определенном расстоянии на плече R.

$$M [\text{Нм}] = F [\text{Н}] \times R [\text{м}]$$

Сервис фактор

Сервис фактор — это количественный показатель тяжести предполагаемых условий работы редуктора, с приблизительным расчетом ежедневного цикла работы, изменений нагрузки и возможных перегрузок, связанных с конкретными условиями эксплуатации.

Приведенный ниже график позволяет найти значение сервис фактора.

* Продолжительность работы час/день

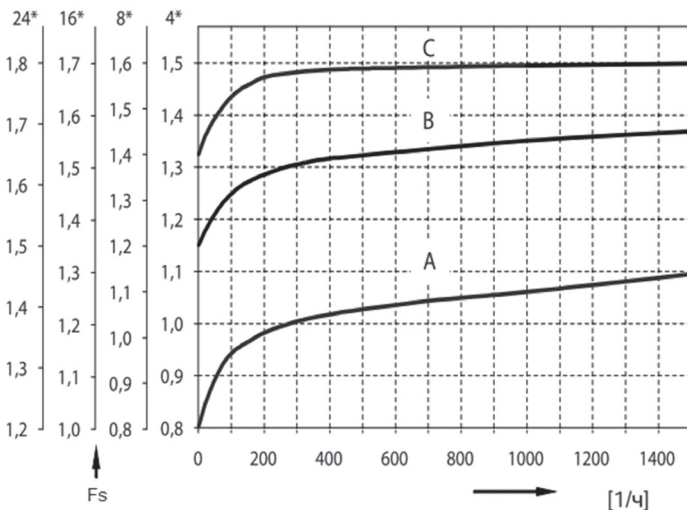

Параметры, которые необходимо учитывать для точного расчета сервис-фактора:

- тип нагрузки рабочего оборудования: А - В - С
- продолжительность рабочего времени: часов/ день (Δ)
- частоту пусков: запусков/час (Z_r)

Тип нагрузки:

- $f_s \leq 0,3$ - кривая А - равномерная нагрузка
- $f_s \leq 3$ - кривая В - умеренные ударные нагрузки
- $f_s \leq 10$ - кривая С - тяжелые ударные нагрузки

При $f_s > 10$ необходимо обратиться в нашу техническую службу.

Примеры типа нагрузки рабочего оборудования:

А - шнеки для подачи легких материалов, вентиляторы, сборочные линии, ленточные конвейеры для легких материалов, малые смесители, подъемники, очистители, заполнители, системы управления.

В - намоточные механизмы, механизмы подачи деревообрабатывающих станков, грузовые лифты, балансиры, резьбонарезные станки, средние смесители, ленточные конвейеры для тяжелых материалов, лебедки, раздвижные дверцы, скребки для удобрений, упаковочные машины, смесители бетона, крановые механизмы, фрезы, гибочные машины, шестеренчатые насосы.

С - смесители для тяжелых материалов, ножницы, прессы, центрифуги, суппорты, лебедки и подъемники для тяжелых материалов, токарно-шлифовальные станки, камнедробилки, ковшовые элеваторы, сверлильные станки, молотковые дробилки, кулачковые прессы, гибочные машины, поворотные столы, очистные барабаны, вибраторы, измельчители.

Сервис фактор редуктора F_s определяет отношение между максимальным крутящим моментом на выходе из редуктора, которым редуктор может быть нагружен и истинным крутящим моментом, который может быть предоставлен подобранным электродвигателем.

$$F_s = M_{\max} / M_{\text{реальный}}$$

Потери от перемешивания масла

Для уменьшения потерь от перемешивания масла рекомендуется использовать для редукторов основную монтажную позицию М1.

МОНТАЖНОЕ ПОЛОЖЕНИЕ

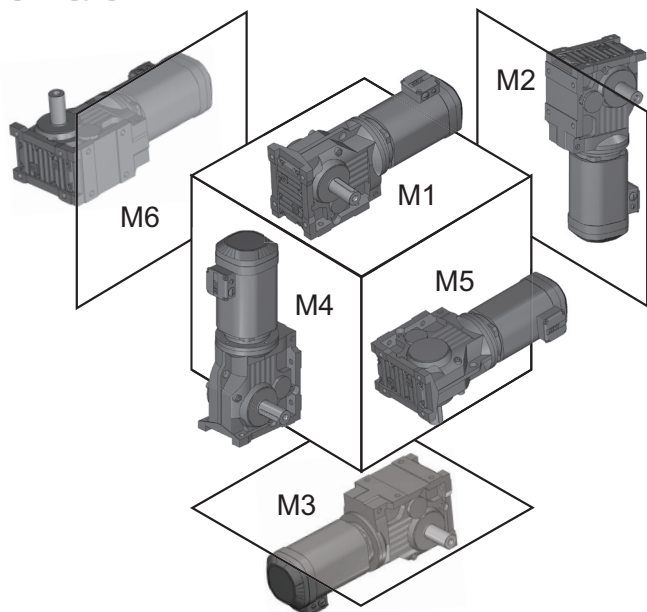

МОНТАЖНОЕ ПОЛОЖЕНИЕ ПЕРВОЙ СТУПЕНИ ОТНОСИТЕЛЬНО ВТОРОЙ СТУПЕНИ СДВОЕННЫХ МОТОР-РЕДУКТОРОВ



ПОЛОЖЕНИЕ РАСПРЕДЕЛИТЕЛЬНОЙ КОРОБКИ ЭЛЕКТРОДВИГАТЕЛЯ

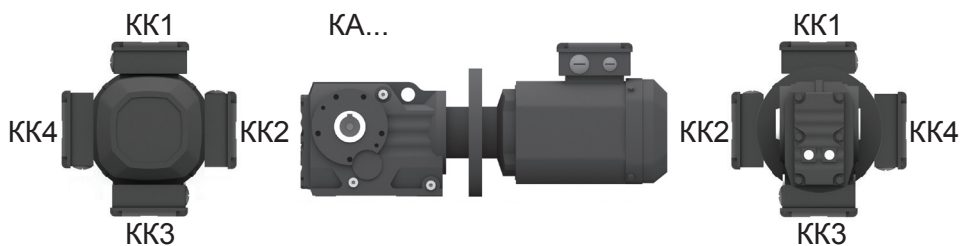

Каталог конических мотор-редукторов

Для работы мотор-редукторов при температуре ниже 0°С необходимо принимать во внимание следующее:

- электродвигатели должны быть рассчитаны на работу при указанной температуре;
- мощность электродвигателя должна выдерживать высокие пусковые моменты;
- в случае редуктора с чугунным корпусом следить за ударными нагрузками, поскольку хрупкость чугуна повышается при -15°С;
- при запуске необходимо, чтобы масло равномерно распределилось в системе и достигло оптимальной температуры и вязкости, для чего рекомендуется дать редуктору поработать несколько минут без нагрузки.

Габарит редуктора	Количество ступеней	D163	D80	D90	D100	D112	D132S	D132M
K/KF/KA/KAF33	3	5.38-106.38	5.38-83.69	5.38-24.99 29.96-72.54	5.36-10.49 13.08-20.19 29.98-58.60			
K/KF/KA/KAF47	3	7.36-11.17 13.65-31.30 39.61-131.87	5.81-104.37	5.81-90.88	5.81-21.81 25.91 35.39-63.30 75.20			
K/KF/KA/KAF57	3	9.59-11.92 19.34-35.70 48.89-145.14	7.55-11.92 15.22-123.85	6.57-108.29	6.57-90.26	6.57-30.28 38.49-76.56		
K/KF/KA/KAF67	3	10.63-12.48 19.30-35.62 48.77-144.79	8.37-12.48 15.19-123.54	7.28-108.03	7.28-90.04	7.28-30.22 38.39-76.37	7.28-24.00 38.39-60.66	7.28-24.00 38.39-60.65
K/KF/KA/KAF77	3	25.62-38.39 64.75-192.16	10.84-12.36 20.25-38.39 51.18-154.05	7.24-1.35.28	7.24-113.58	7.24-97.05	7.24-30.89 40.04-78.07	7.24-30.89 40.04-76.07
K/KF/KA/KAF87	3		16.00 27.88-31.39 70.46-197.37	11.17 16.00 19.45-31.39 49.16-174.19	8.29-11.17 14.45-147.32	8.29-11.17 14.45-126.91	7.21-102.71	7.21-102.71
K/KF/KA/KAF97	3			24.75-38.30 62.55-176.05	18.98-38.30 47.93-178.05	19.98-38.30 47.93-153.21	8.71-123.93	8.71-123.93
K/KF/KA/KAF107	3				13.43 22.62-29.00 32.69 57.17-143.47	13.43 22.62-29.00 32.69 57.17-143.47	8.69-29.00 32.69-143.47	8.69-29.00 32.69-143.47
K/KF/KA/KAF127	3							12.79 21.15-36.25 47.82-146.07

Габарит редуктора	Количество ступеней	D132ML	D160M	D160L	D180	D200
K/KF/KA/KAF77	3	7.24-23.08 40.04-58.34	7.24-23.08 40.04-58.34			
K/KF/KA/KAF87	3	7.21-79.34	7.21-79.34	7.21-79.34	7.21-14.45 17.42-24.92 36.52-63.00	
K/KF/KA/KAF97	3	8.71-98.80	8.71-96.80	8.71-96.80	8.71-30.82 41.87-77.89	8.71-24.75 41.87-62.55
K/KF/KA/KAF107	3	8.69-112.41	8.69-112.41	8.69-112.41	8.69-90.98	8.69-31.28 37.00-73.30
K/KF/KA/KAF127	3	10.74-12.79 17.77-136.14	10.74-12.79 17.77-136.14	10.74-12.79 17.77-136.14	8.68-110.18	8.68-89.89
K/KF/KA/KAF157	3		18.37-31.30 46.79-150.41	18.37-31.30 46.79-150.41	14.92-122.39	12.65-100.22
K/KH167	3		24.52-32.25 51.77-164.50	24.52-32.25 51.77-164.50	20.32-32.25 42.89-134.99	17.34-109.83
K/KH187	3		33.23-42.51 88.00-179.88	33.23-42.51 88.00-179.88	27.92-42.51 73.96-179.86	17.18-179.86

Габарит редуктора	Количество ступеней	D225	D250M	D280	D315	D315M_A/B
K/KF/KA/KAF107	3	8.69-31.28 37.00-73.30				
K/KF/KA/KAF127	3	8.68-89.89	8.68-31.37 40.19-70.95	8.68-31.37 40.19-70.95		
K/KF/KA/KAF157	3	12.65-100.22	12.65-79.76	12.65-79.76	12.65-23.95 38.02-61.02	12.65-18.37 38.02-46.79
K/KH167	3	17.34-109.83	17.34-87.86	17.34-87.86	17.34-68.07	17.34-24.52 36.81-51.77
K/KH187	3	17.18-179.86	17.18-144.59	17.18-144.59	17.18-112.50	17.18-33.23 45.50-88.00

НОМИНАЛЬНЫЕ ЗНАЧЕНИЯ ОСНОВНЫХ ПАРАМЕТРОВ

i	n_2 [об/мин]	M [Нм]	F_{r2} [Н]	AD
К37 200Нм				
106.38	13	200	5640	AD ₁
97.81	14	200	5640	
83.69	17	200	5640	
72.54	19	200	5520	
67.80	21	200	5360	
58.60	24	200	5020	
49.79	28	200	4660	
44.46	31	200	4420	
37.97	37	200	4100	
35.57	39	200	3970	
К47 400 Нм				
29.96	47	200	3650	AD ₂
28.83	49	200	3530	
24.99	56	200	3330	
23.36	60	195	3260	
20.19	69	185	3110	
17.15	82	180	2900	
15.31	91	175	2780	
13.08	107	165	2650	
12.14	115	160	2600	
10.49	133	160	2410	
К57 600 Нм				
8.91	157	160	2200	AD ₃
7.96	176	155	2110	
6.80	206	150	1980	
6.37	220	145	1860	
5.36	261	140	1810	

i	n_2 [об/мин]	M [Нм]	F_{r2} [Н]	AD
К47 400 Нм				
131.87	11	400	5920	AD ₂
121.48	12	400	5920	
104.37	13	400	5920	
90.88	15	400	5920	
85.12	16	400	5920	
75.20	19	400	5920	
69.84	20	400	5920	
63.30	22	400	5920	
56.83	25	400	5920	
48.95	29	400	5920	
К57 600 Нм				
44.03	30	400	5920	AD ₂
39.61	35	400	5920	
35.35	40	400	5920	
31.30	45	400	5700	
29.32	48	400	5520	
25.91	54	400	5170	
24.08	58	400	4970	
21.81	64	400	4710	
19.58	72	400	4440	
16.86	83	380	4230	
К67 820 Нм				
15.86	88	380	4080	AD ₃
13.65	103	360	3890	
12.19	115	350	3720	
11.77	119	280	4080	
10.56	133	280	3830	
9.10	154	280	3540	
8.58	164	270	3500	
7.35	190	250	3390	
6.58	213	240	3270	
5.81	241	230	3140	

i	n_2 [об/мин]	M [Нм]	F_{r2} [Н]	AD
К57 600 Нм				
145.14	9.6	600	7470	AD ₂
123.85	11	600	7470	
108.29	13	600	7470	
102.88	14	600	7470	
90.25	16	600	7470	
76.58	18	600	7470	
69.12	20	600	7470	
60.81	23	600	7470	
57.42	24	600	7470	
48.89	29	600	7470	
К67 820 Нм				
44.43	32	600	7470	AD ₂
38.49	36	600	7470	
35.70	39	600	7470	
30.28	46	600	7310	
27.34	51	600	6930	
24.05	58	600	6480	
22.71	62	600	6280	
19.34	72	575	5910	
17.57	80	555	5740	
15.22	92	535	5430	
К77 1550 Нм				
13.25	106	510	5190	AD ₃
11.92	117	415	5150	
11.26	124	415	4900	
9.59	146	405	4850	
8.71	161	390	4520	
7.55	185	365	4360	
6.57	213	345	4190	

i	n_2 [об/мин]	M [Нм]	F_{r2} [Н]	AD
К67 820 Нм				
144.79	9.7	820	10300	AD ₂
123.54	11	820	10300	
108.03	13	820	10300	
102.62	14	820	10300	
90.04	16	820	10300	
76.37	18	820	10300	
68.95	20	820	10300	
60.88	23	820	10300	
57.28	24	820	10300	
48.77	29	820	10300	
К77 1550 Нм				
44.32	32	820	10300	AD ₃
38.39	36	820	10500	
35.62	39	820	10300	
30.22	46	820	10300	
27.28	51	820	10300	
24.00	58	800	10500	
22.66	62	730	10700	
19.30	73	760	10800	
17.54	80	740	11000	
15.19	92	700	11300	
К87 2700 Нм				
13.22	106	670	11500	AD ₄
12.48	112	630	12300	
10.83	132	600	11800	
9.66	145	480	11500	
8.37	167	440	11100	
7.28	192	420	10700	

i	n_2 [об/мин]	M [Нм]	F_{r2} [Н]	AD
К77 1550 Нм				
192.18	7.3	1450	16100	AD ₂
179.37	7.8	1450	16100	
154.02	9.1	1550	15400	
135.28	10	1550	15400	
12852	11	1550	15400	
113.56	12	1550	15400	
97.05	14	1550	15400	
88.97	16	1550	15400	
78.07	18	1550	15400	
73.99	19	1550	15400	
К87 2700 Нм				
64.75	22	1550	15400	AD ₂
58.34	24	1550	15400	
51.18	27	1550	15400	
45.18	31	1550	15400	
40.04	35	1550	15400	
38.39	36	1550	15700	
35.20	40	1550	15400	
30.89	45	1550	15400	
29.27	46	1550	15400	
25.62	55	1550	15400	
К97 4000 Нм				
23.08	61	1550	15400	AD ₃
20.25	69	1500	15700	
17.87	78	1450	16100	
15.84	88	1400	15500	
13.52	104	1340	14800	
12.38	113	1000	15100	
10.84	129	990	14400	
9.56	146	940	13900	
8.48	165	890	13500	
7.24	193	820	13100	

i	n_2 [об/мин]	M [Нм]	F_{r2} [Н]	AD
К87 2700 Нм				
197.37	7.1	2700	27300	AD ₂
174.19	8.0	2700	27300	
164.34	8.5	2700	27300	
147.32	9.5	2700	27300	
126.91	11	2700	27300	
115.82	12	2700	27300	
102.71	14	2700	27300	
86.34	16	2700	27300	
79.34	18	2700	27300	
70.46	20	2700	27300	
К97 4000 Нм				
63.00	22	2700	26200	AD ₃
56.64	25	2700	25000	
49.46	28	2700	23500	
44.02	32	2600	22800	
36.52	38	2500	21400	
31.39	45	2700	19200	
27.88	50	2600	18500	
24.92	56	2500	18000	
22.41	62	2300	17900	
19.45	72	2300	18800	
К107 5500 Нм				
17.42	80	2200	18300	AD ₄
16.00	87	1800	18000	
14.45	97	2100	15300	
12.56	111	2000	14800	
11.17	125	1500	14900	
10.00	140	1500	14200	
8.29	169	1400	13500	
7.21	194	1300	13200	

i	n_2 [об/мин]	M [Нм]	F_{r2} [Н]	AD
K97			4300 Нм	
176.05	8.0	4300	40000	AD ₃
153.21	9.1	4300	40000	
140.28	10	4300	40000	
123.93	11	4300	40000	
105.13	13	4300	40000	
96.80	14	4300	40000	
86.52	16	4300	38800	
77.89	18	4300	37100	
70.54	20	4300	35600	
62.55	22	4300	33800	
56.55	25	4300	32300	AD ₄
47.93	29	4300	30000	
41.87	33	4300	28300	
38.30	37	4300	27100	AD ₅
34.23	41	4300	25700	
30.82	45	4300	24500	
27.91	50	4300	23300	
24.75	57	4300	22000	
22.37	63	4300	20900	
18.96	74	4300	19100	
16.56	85	4300	17800	
13.85	101	4300	18100	
11.99	117	3880	16200	
10.41	134	2870	16400	AD ₅
8.71	161	2880	15800	AD ₆

i	n_2 [об/мин]	M [Нм]	F_{r2} [Н]	AD
K107			8000 Нм	
143.47	9.8	8000	65000	AD ₄
121.46	12	8000	61700	
112.41	12	8000	59700	
100.75	14	8000	57000	
90.96	15	8000	54600	
82.61	17	8000	52400	
73.30	19	8000	46700	
68.52	21	8000	47600	
57.17	24	8000	44400	
49.80	28	7840	42200	
42.33	33	7380	40500	AD ₅
37.00	38	7200	38500	
32.69	43	7200	38300	
31.28	45	6800	36700	AD ₆
29.00	48	7200	34000	
26.32	53	7200	32000	
22.62	62	7200	28900	
19.74	71	7200	28100	
16.75	84	7050	23600	
14.64	98	6890	21900	
13.43	104	4300	29200	
11.73	119	4300	27600	
9.94	141	4190	25800	
8.69	161	4070	24600	

i	n_2 [об/мин]	M [Нм]	F_{r2} [Н]	AD
K127			13000 Нм	
146.07	9.6	13000	79200	AD ₄
136.14	10	13000	79200	
122.48	11	13000	79200	
110.18	13	13000	79200	AD ₅
89.89	16	13000	75100	
81.98	17	13000	72100	
70.95	20	13000	67700	
62.60	22	13000	64000	
54.07	26	13000	59900	
47.82	29	13000	56500	
40.19	35	13000	52000	
36.25	39	13000	49400	AD ₇
31.37	45	13000	45900	
27.68	51	13000	43000	
23.91	59	13000	39800	AD ₈
21.15	66	13000	37200	
17.77	79	13000	33800	
14.35	98	12100	31800	
12.79	109	8530	35400	
10.74	130	8000	33900	
8.68	161	7230	32500	

i	n_2 [об/мин]	M [Нм]	F_{r2} [Н]	AD
K157			18000 Нм	
150.41	9.3	18000	112200	AD ₅
122.39	11	18000	106500	
100.22	14	18000	98000	
91.65	15	18000	94400	
79.75	18	18000	88900	
70.38	20	18000	84200	
61.02	23	18000	78000	
54.29	26	18000	74900	
46.79	30	18000	70000	
38.02	37	18000	63300	
31.30	45	18000	57500	AD ₇
27.62	51	18000	54000	
23.95	58	18000	50000	
21.31	66	18000	47000	AD ₈
18.37	76	18000	43200	
14.92	94	18000	38200	
12.85	111	17000	38700	

i	n_2 [об/мин]	M [Нм]	F_{r2} [Н]	AD
K167			32000 Нм	
164.50	8.5	32000	150000	AD ₅
134.99	10	32000	150000	AD ₆
109.83	13	32000	150000	
87.86	16	32000	147200	AD ₇
78.14	18	32000	140100	
68.07	21	32000	132000	
60.74	23	32000	125600	AD ₈
51.77	27	32000	117000	
42.89	33	32000	107400	
36.61	38	32000	99700	
32.25	43	32000	93700	
28.77	49	32000	88600	
24.52	57	32000	81700	
20.32	69	32000	74000	
17.34	81	32000	87800	

i	n_2 [об/мин]	M [Нм]	F_{r2} [Н]	AD
K187			50000 Нм	
179.86	7.8	50000	190000	AD ₆
165.21	8.5	50000	190000	
144.59	9.7	50000	190000	
129.69	11	50000	188200	AD ₇
112.60	12	50000	177200	
102.16	14	50000	189900	AD ₈
88.00	16	50000	159000	
73.98	19	50000	147000	
64.04	22	50000	137500	
53.38	26	50000	126000	
45.50	31	50000	116600	
42.51	33	50000	112700	
38.57	36	50000	107200	
33.23	42	50000	89100	
27.92	50	50000	90200	
24.18	58	47600	86800	
20.15	69	43900	84000	
17.18	81	41400	80800	

Каталог конических мотор-редукторов

i	n_2 [об/мин]	M [Нм]	F_{r_2} [Н]
К37 R17		200 Нм	
6832	0.20	200	5640
5922	0.24	200	5640
5491	0.25	200	5640
4759	0.29	200	5640
4160	0.34	200	5640
3845	0.38	200	5640
3205	0.44	200	5640
2801	0.50	200	5640
2454	0.57	200	5640
2166	0.65	200	5640
1891	0.74	200	5640
1660	0.84	200	5640
1466	0.85	200	5640
1288	1.1	200	5640
1138	1.2	200	5640
998	1.4	200	5640
876	1.6	200	5640
781	1.8	200	5640
671	2.1	200	5640
585	2.4	200	5640
512	2.7	200	5640
451	3.1	200	5640
398	3.5	200	5640
346	4.0	200	5640
304	4.6	200	5640
267	5.2	200	5640
234	6.0	200	5640
205	6.8	200	5640
181	7.7	200	5640
180	8.8	200	5640
136	10	200	5640
127	11	200	5640
110	13	200	5640
96	15	200	5640

i	n_2 [об/мин]	M [Нм]	F_{r_2} [Н]
К47 R37		400Нм	
10138	0.14	400	5920
8534	0.16	400	5920
7662	0.18	400	5920
8828	0.21	400	5920
5883	0.23	400	5920
5159	0.27	400	5920
4601	0.30	400	5920
3940	0.36	400	5920
3477	0.40	400	5920
3043	0.46	400	5920
2733	0.51	400	5920
2354	0.59	400	5920
2083	0.68	400	5920
1819	0.77	400	5920
1586	0.88	400	5920
1388	1.0	400	5920
1222	1.1	400	5920
1097	1.3	400	5920
945	1.5	400	5920
831	1.7	400	5920
718	1.9	400	5920
639	2.2	400	5920
552	2.5	400	5920
485	2.8	400	5920
428	3.3	400	5920
375	3.7	400	5920
327	4.3	400	5920
289	4.8	400	5920
256	5.5	400	5920
225	6.2	400	5920
188	7.1	400	5920
171	8.2	400	5920
153	9.2	400	5920
131	11	400	5920
112	13	400	5920
99	14	400	5920
94	15	400	5920

i	n_2 [об/мин]	M [Нм]	F_{r_2} [Н]
К57 R37		600 Нм	
12169	0.12	600	7470
11162	0.13	600	7470
9503	0.15	600	7470
8547	0.16	600	7470
7277	0.19	600	7470
6478	0.22	600	7470
5662	0.25	600	7470
5033	0.28	600	7470
4340	0.32	600	7470
3854	0.36	600	7470
3390	0.41	600	7470
2924	0.48	600	7470
2593	0.54	600	7470
2249	0.62	600	7470
1986	0.70	600	7470
1743	0.80	600	7470
1539	0.91	600	7470
1354	1.0	600	7470
1174	1.2	600	7470
1036	1.4	600	7470
906	1.5	600	7470
806	1.7	600	7470
699	2.0	600	7470
615	2.3	600	7470
544	2.6	600	7470
473	3.0	600	7470
421	3.3	600	7470
362	3.9	600	7470
319	4.4	600	7470
280	5.0	600	7470
246	5.7	600	7470
215	6.5	600	7470
192	7.3	600	7470
166	8.4	600	7470
145	9.7	600	7470
129	11	600	7470
111	13	600	7470
97	14	600	7470

i	n_2 [ОБ/МИН]	M [НМ]	F_{r_2} [Н]
K67 R37		820 Нм	
12139	0.12	820	10300
11134	0.13	820	10300
9479	0.15	820	10300
8173	0.17	820	10300
7259	0.19	820	10300
6482	0.22	820	10300
5648	0.25	820	10300
4846	0.29	820	10300
4329	0.32	820	10300
3750	0.37	820	10300
3315	0.42	820	10300
2917	0.48	820	10300
2532	0.55	820	10300
2244	0.62	820	10300
1981	0.71	820	10300
1739	0.81	820	10300
1535	0.91	820	10300
1351	1.0	820	10300
1171	1.2	820	10300
1034	1.4	820	10300
903	1.6	820	10300
793	1.8	820	10300
697	2.0	820	10300
613	2.3	820	10300
542	2.6	820	10300
471	3.0	820	10300
420	3.3	820	10300
361	3.9	820	10300
323	4.3	820	10300
279	5.0	820	10300
246	5.7	820	10300
217	6.5	820	10300
191	7.3	820	10300
166	8.4	820	10300
144	9.7	820	10300
122	11	820	10300

i	n_2 [ОБ/МИН]	M [НМ]	F_{r_2} [Н]
K77 R37		1550 Нм	
15310	0.09	1550	15400
14043	0.10	1550	15400
11955	0.12	1550	15400
10217	0.14	1550	15400
8809	0.16	1550	15400
7528	0.19	1550	15400
6606	0.21	1550	15400
5774	0.24	1550	15400
5089	0.28	1550	15400
4489	0.31	1550	15400
3961	0.35	1550	15400
3485	0.40	1550	15400
2901	0.48	1550	15400
2717	0.52	1550	15400
2370	0.59	1550	15400
2050	0.68	1550	15400
1772	0.79	1550	15400
1514	0.92	1550	15400
1388	1.0	1550	15400
1218	1.1	1550	15400
1053	1.3	1550	15400
924	1.5	1550	15400
815	1.7	1550	15400
709	2.0	1550	15400
622	2.3	1550	15400
552	2.5	1550	15400
485	2.9	1550	15400
428	3.3	1550	15400
367	3.8	1550	15400
328	4.3	1550	15400
290	4.8	1550	15400
252	5.6	1550	15400
221	6.3	1550	15400
195	7.2	1550	15400
175	8.0	1550	15400
154	9.1	1550	15400

i	n_2 [ОБ/МИН]	M [НМ]	F_{r_2} [Н]
K87 R57		2700 Нм	
14829	0.09	2700	27300
13168	0.11	2700	27300
11737	0.12	2700	27300
10217	0.14	2700	27300
9073	0.15	2700	27300
7854	0.18	2700	27300
6832	0.20	2700	27300
5930	0.24	2700	27300
5240	0.27	2700	27300
4562	0.31	2700	27300
4037	0.35	2700	27300
3609	0.39	2700	27300
3107	0.45	2700	27300
2728	0.51	2700	27300
2371	0.59	2700	27300
2088	0.67	2700	27300
1854	0.76	2700	27300
1657	0.84	2700	27300
1415	0.99	2700	27300
1229	1.1	2700	27300
1078	1.3	2700	27300
951	1.6	2700	27300
837	1.7	2700	27300
726	1.9	2700	27300
638	2.2	2700	27300
562	2.5	2700	27300
474	3.0	2700	27300
426	3.3	2700	27300
373	3.8	2700	27300
330	4.2	2700	27300
294	4.8	2700	27300
250	5.6	2700	27300
236	5.9	2700	27300
201	7.0	2700	27300
183	7.7	2700	27300
158	8.8	2700	27300
141	9.9	2700	27400

Каталог конических мотор-редукторов

i	n_2 [об/мин]	M [Нм]	F_r [Н]
K97 R57		4300 Нм	
18091	0.08	4300	40000
16666	0.08	4300	40000
14897	0.09	4300	40000
13182	0.11	4300	40000
11677	0.12	4300	40000
10317	0.14	4300	40000
9083	0.15	4300	40000
8054	0.17	4300	40000
6970	0.20	4300	40000
6027	0.23	4300	40000
5391	0.26	4300	40000
4669	0.30	4300	40000
4082	0.34	4300	40000
3583	0.39	4300	40000
3108	0.45	4300	40000
2757	0.51	4300	40000
2419	0.58	4300	40000
2123	0.66	4300	40000
1858	0.75	4300	40000
1625	0.86	4300	40000
1430	0.98	4300	40000
1261	1.1	4300	40000
1102	1.3	4300	40000
957	1.5	4300	40000
855	1.6	4300	40000
743	1.9	4300	40000
652	2.1	4300	40000
573	2.4	4300	40000
504	2.8	4300	40000
437	3.2	4300	40000
382	3.7	4300	40000
342	4.1	4300	40000
305	4.6	4300	40000
258	5.4	4300	40000
232	6.0	4300	40000
100	7.0	4300	40000

i	n_2 [об/мин]	M [Нм]	F_r [Н]
K107 R77		8000 Нм	
14311	0.10	8000	65000
12211	0.11	8000	65000
10677	0.13	8000	65000
9524	0.15	8000	65000
8328	0.17	8000	65000
7270	0.19	8000	65000
6184	0.23	8000	65000
5662	0.25	8000	65000
5138	0.27	8000	65000
4359	0.32	8000	65000
3810	0.37	8000	65000
3358	0.42	8000	65000
2977	0.47	8000	65000
2599	0.54	8000	65000
2286	0.61	8000	65000
1939	0.72	8000	65000
1713	0.82	8000	65000
1554	0.90	8000	65000
1336	1.0	8000	65000
1166	1.2	8000	65000
1030	1.4	8000	65000
904	1.5	8000	65000
793	1.8	8000	65000
696	2.0	8000	65000
615	2.3	8000	65000
522	2.7	8000	65000
461	3.0	8000	65000
408	3.4	8000	65000
364	3.8	8000	65000
318	4.4	8000	65000
286	4.9	8000	65000
251	5.6	8000	65000
222	6.3	8000	65000
196	7.1	8000	65000
174	8.0	7200	65000
154	9.1	7200	65000
140	10	7200	65000

i	n_2 [об/мин]	M [Нм]	F_r [Н]
K127 R77		13000 Нм	
17550	0.08	13000	79200
16006	0.09	13000	79200
14975	0.09	13000	79200
12440	0.11	13000	79200
10915	0.13	13000	79200
9819	0.14	13000	79200
8443	0.17	13000	79200
7482	0.19	13000	79200
6565	0.21	13000	79200
5804	0.24	13000	79200
5027	0.28	13000	79200
4423	0.32	13000	79200
3889	0.36	13000	79200
3311	0.42	13000	79200
3009	0.47	13000	79200
2607	0.54	13000	79200
2288	0.62	13000	79200
1926	0.73	13000	79200
1767	0.80	13000	79200
1541	0.91	13000	79200
1342	1.0	13000	79200
1177	1.2	13000	79200
1025	1.4	13000	79200
899	1.6	13000	79200
790	1.8	13000	79200
704	2.0	13000	79200
610	2.3	13000	79200
549	2.6	13000	79200
477	2.9	13000	79200
418	3.3	13000	79200

i	n_2 [ОБ/МИН]	M [Нм]	Fr_2 [Н]
K127 R87 13000 Нм			
536	2.6	13000	79200
473	3.0	13000	79200
418	3.3	13000	79200
367	3.8	13000	79200
330	4.2	13000	79200
287	4.9	13000	79200
253	5.5	13000	79200
213	6.6	13000	79200
200	7.0	13000	79700
166	8.4	13000	79700
147	9.5	13000	79700

i	n_2 [ОБ/МИН]	M [Нм]	Fr_2 [Н]
K157 R97 18000 Нм			
17679	0.08	18000	112200
15729	0.09	18000	112200
14721	0.10	18000	112200
13097	0.11	18000	112200
11368	0.12	18000	112200
10114	0.14	18000	112200
8718	0.16	18000	112200
7734	0.18	18000	112200
6881	0.20	18000	112200
5931	0.24	18000	112200
5074	0.28	18000	112200
4514	0.31	18000	112200
3979	0.35	18000	112200
3516	0.40	18000	112200
3051	0.46	18000	112200
2610	0.54	18000	112200
2322	0.60	18000	112200
2029	0.69	18000	112200
1805	0.78	18000	112200
1659	0.84	18000	112200
1365	1.0	18000	112200
1229	1.1	18000	112200
1093	1.3	18000	112200
942	1.5	18000	112200
854	1.6	18000	112200
756	1.9	18000	112200
661	2.1	18000	112200
567	2.5	18000	112200
504	2.8	18000	112200
434	3.2	18000	112200
379	3.7	18000	112200
333	4.2	18000	112200
291	4.8	18000	112200

i	n_2 [ОБ/МИН]	M [Нм]	Fr_2 [Н]
K157 R107 18000Нм			
385	3.6	18000	112200
325	4.3	18000	111200
299	4.7	18000	111200
253	5.5	18000	112200
230	6.1	18000	111200
213	6.6	18000	111200
187	7.5	18000	112200
157	8.9	18000	111200
122	11	18000	106500
107	13	18000	100700

i	n_2 [ОБ/МИН]	M [Нм]	Fr_2 [Н]
K167 R97 32000Нм			
19723	0.07	32000	150000
17406	0.08	32000	150000
15000	0.09	32000	150000
13238	0.11	32000	150000
11573	0.12	32000	150000
10264	0.14	32000	150000
8628	0.16	32000	150000
6562	0.21	32000	150000
5355	0.26	32000	150000
4788	0.29	32000	150000
4079	0.34	32000	150000
3376	0.41	32000	150000
2755	0.51	32000	150000
2263	0.62	32000	150000
2182	0.64	32000	150000
1704	0.82	32000	150000
1408	0.99	32000	150000
1296	1.1	32000	150000
1101	1.3	32000	150000
944	1.5	32000	150000
843	1.7	32000	150000
757	1.8	32000	150000
632	2.2	32000	150000
561	2.5	32000	150000
481	2.9	32000	150000
423	3.3	32000	150000
369	3.8	32000	150000

i	n_2 [ОБ/МИН]	M [Нм]	Fr_2 [Н]
K167 R107 32000Нм			
318	4.4	32000	150000
278	5.0	32000	150000
244	5.7	32000	150000
213	6.6	32000	150000
206	6.8	32000	150000
180	7.8	32000	150000
160	8.8	32000	150000
135	10	32000	150000
118	12	32000	150000

i	n_2 [ОБ/МИН]	M [Нм]	Fr_2 [Н]
K187 R97 5000Нм			
32625	0.04	50000	190000
27165	0.05	50000	190000
24353	0.06	50000	190000
19144	0.07	50000	190000
16978	0.08	50000	190000
14272	0.10	50000	190000
13116	0.11	50000	190000
11647	0.12	50000	190000
10413	0.13	50000	190000
9363	0.15	50000	190000
8126	0.17	50000	190000
7343	0.19	50000	190000
6747	0.21	50000	190000
5991	0.23	50000	190000
5358	0.26	50000	190000
4817	0.29	50000	190000
4370	0.32	50000	190000
3609	0.39	50000	190000
3062	0.46	50000	190000
2818	0.50	50000	190000
2519	0.56	50000	190000
2268	0.62	50000	190000
2054	0.68	50000	190000
1821	0.77	50000	190000
1605	0.87	50000	190000
1395	1.0	50000	190000
1196	1.2	50000	190000
1046	1.3	50000	190000
945	1.5	50000	190000
738	1.9	50000	190000
621	2.3	50000	190000
527	2.7	50000	190000

i	n_2 [ОБ/МИН]	M [Нм]	Fr_2 [Н]
K187 R107 50000Нм			
835	1.7	50000	190000
729	1.9	50000	190000
622	2.3	50000	190000
520	2.7	50000	190000
454	3.1	50000	190000
355	3.9	50000	190000
261	5.4	50000	190000
221	6.3	50000	190000
193	7.3	50000	190000
163	8.6	50000	190000

Каталог конических мотор-редукторов

n2 [1/МИН]	M [H*М]	i	Fr2 [N]	fs	Редуктор + ПАМ
0.12 кВт					
0.08	11800	17550	79800	1.10	
0.09	10700	16006	80400	1.20	
0.09	9880	14975	80700	1.30	K 127 R67 ESQ 63A4
0.11	8010	12440	81500	1.60	KF 127 R67 ESQ 63A4
0.13	6920	10915	81800	1.90	KA 127 R67 ESQ 63A4
0.14	6320	9819	82000	2.1	KAF 127 R67 ESQ 63A4
0.16	5220	8443	82300	2.5	
0.18	4820	7482	82300	2.7	
0.10	9590	14311	65000	0.85	
0.11	8060	12211	65000	1.00	
0.13	6930	10677	65000	1.15	
0.14	6280	9524	65000	1.25	K 107 R77 ESQ 63A4
0.17	5410	8328	65000	1.50	KF 107 R77 ESQ 63A4
0.19	4720	7270	65000	1.70	KA 107 R77 ESQ 63A4
0.22	3760	6184	65000	2.1	KAF 107 R77 ESQ 63A4
0.24	3320	5662	65000	2.4	
0.27	3020	5138	65000	2.7	
0.32	2700	4359	65000	3.0	
0.17	5310	8054	39500	0.80	
0.20	4350	6970	40000	1.00	
0.23	3890	6027	40000	1.10	K 97 R57 ESQ 63A4
0.26	3560	5391	40000	1.20	KF 97 R57 ESQ 63A4
0.30	2950	4669	40000	1.45	KA 97 R57 ESQ 63A4
0.34	2640	4082	40000	1.65	KAF 97 R57 ESQ 63A4
0.39	2320	3583	40000	1.85	
0.44	2040	3108	40000	2.1	
0.50	1720	2757	40000	2.5	
0.57	1580	2419	40000	2.7	
0.65	1370	2123	40000	3.2	K 97 R57 ESQ 63A4
0.74	1220	1856	40000	3.5	KF 97 R57 ESQ 63A4
0.85	1000	1625	40000	4.3	KA 97 R57 ESQ 63A4
0.96	860	1430	40000	5.0	KAF 97 R57 ESQ 63A4
1.1	830	1261	40000	5.2	
1.2	725	1102	40000	5.9	
0.26	3380	5240	26300	0.80	
0.30	2850	4562	27100	0.95	K 87 R57 ESQ 63A4
0.34	2610	4037	27400	1.05	KF 87 R57 ESQ 63A4
0.38	2330	3609	27700	1.15	KA 87 R57 ESQ 63A4
0.44	1990	3107	28100	1.35	KAF 87 R57 ESQ 63A4
0.51	1700	2728	28300	1.60	
0.58	1500	2371	28500	1.80	
0.66	1380	2088	28600	1.95	
0.74	1220	1854	28700	2.2	
0.83	1090	1657	28700	2.5	K 87 R57 ESQ 63A4
0.97	930	1415	28800	2.9	KF 87 R57 ESQ 63A4
1.1	800	1229	28900	3.4	KA 87 R57 ESQ 63A4
1.3	695	1078	28900	3.9	KAF 87 R57 ESQ 63A4
1.5	585	951	29000	4.6	
1.6	505	837	29000	5.4	
1.9	435	726	29000	6.2	
0.51	1790	2718	13400	0.85	K 77 R37 ESQ 63A4
					KF 77 R37 ESQ 63A4
0.58	1510	2370	15700	1.05	KA 77 R37 ESQ 63A4
					KAF 77 R37 ESQ 63A4
0.67	1380	2050	16500	1.10	
0.78	1180	1772	17500	1.30	
0.91	1010	1514	18300	1.55	
0.99	920	1388	18600	1.70	K 77 R37 ESQ 63A4
1.1	810	1218	19000	1.90	KF 77 R37 ESQ 63A4
1.3	710	1053	19200	2.2	KA 77 R37 ESQ 63A4
1.5	620	924	19500	2.5	KAF 77 R37 ESQ 63A4
1.7	550	815	19600	2.8	
2.0	440	709	19800	3.5	
2.2	385	622	19900	4.0	

n2 [1/МИН]	M [H*М]	i	Fr2 [N]	fs	Редуктор + ПАМ
1.0	930	1351	9230	0.90	
1.2	795	1171	10500	1.05	
1.3	695	1034	11300	1.20	
1.5	585	903	12000	1.40	
1.7	545	793	12200	1.50	
2.0	440	697	12700	1.85	K 67 R37 ESQ 63A4
2.2	390	613	12900	2.1	KF 67 R37 ESQ 63A4
2.5	340	542	13000	2.4	KA 67 R37 ESQ 63A4
2.9	315	471	13000	2.6	KAF 67 R37 ESQ 63A4
3.3	265	420	13000	3.1	
3.8	235	361	13000	3.5	
4.3	210	323	13000	3.9	
4.9	176	279	13000	4.7	
5.6	155	246	13000	5.3	
6.3	134	217	13000	6.1	
1.5	585	906	7750	1.05	
1.7	525	806	8220	1.15	
2.0	445	699	8690	1.35	
2.2	390	615	8930	1.55	
2.5	340	544	9120	1.75	
2.9	310	473	9250	1.95	K 57 R37 ESQ 63A4
3.3	265	421	9420	2.3	KF 57 R37 ESQ 63A4
3.8	235	362	9510	2.5	KA 57 R37 ESQ 63A4
4.3	210	319	9610	2.9	KAF 57 R37 ESQ 63A4
4.9	176	280	9710	3.4	
5.6	155	246	9770	3.9	
6.4	135	215	9830	4.4	
7.2	122	192	9860	4.9	
2.2	430	639	2520	0.95	
2.5	370	552	6350	1.10	
2.8	315	495	6930	1.25	K 47 R37 ESQ 63A4
3.2	280	426	7240	1.45	KF 47 R37 ESQ 63A4
3.7	235	375	7560	1.70	KA 47 R37 ESQ 63A4
4.2	215	327	7670	1.85	KAF 47 R37 ESQ 63A4
4.8	189	289	7830	2.1	
4.0	235	346	4840	0.85	
4.5	200	304	5640	1.00	
5.2	182	267	5830	1.10	K 37 R17 ESQ 63A4
5.9	157	234	6060	1.25	KF 37 R17 ESQ 63A4
6.7	138	205	6220	1.45	KA 37 R17 ESQ 63A4
7.6	120	181	6330	1.65	KAF 37 R17 ESQ 63A4
8.6	105	160	6420	1.90	
10	88	136	6500	2.3	
6.2	184	144.79	13000	4.4	K 67 ESQ 63B6
					KF 67 ESQ 63B6
					KA 67 ESQ 63B6
					KAF 67 ESQ 63B6
6.2	185	145.14	9680	3.2	
7.3	158	123.85	9760	3.8	K 57 ESQ 63B6
8.3	138	108.29	9820	4.3	KF 57 ESQ 63B6
8.8	131	102.88	9840	4.6	KA 57 ESQ 63B6
10	115	90.26	9880	5.2	KAF 57 ESQ 63B6
12	98	76.56	9930	6.2	
9.5	121	145.14	9870	5.0	K 57 ESQ 63A4
11	103	123.85	9920	5.8	KF 57 ESQ 63A4
13	90	108.29	9950	6.7	KA 57 ESQ 63A4
13	85	102.88	9960	7.0	KAF 57 ESQ 63A4
15	75	90.26	9990	8.0	
6.8	168	131.87	7930	2.4	K 47 ESQ 63B6
7.4	155	121.48	7990	2.6	KF 47 ESQ 63B6
8.6	133	104.37	8070	3.0	KA 47 ESQ 63B6
					KAF 47 ESQ 63B6
10	110	131.87	8140	3.7	K 47 ESQ 63A4
					KF 47 ESQ 63A4
					KA 47 ESQ 63A4
					KAF 47 ESQ 63A4

n2 [1/мин]	M [H*М]	i	Fr2 [N]	fs	Редуктор + РАМ
8.5	136	106.38	6230	1.50	K 37 ESQ 63B6
9.2	125	97.81	6300	1.60	KF 37 ESQ 63B6
11	107	83.69	6410	1.90	KA 37 ESQ 63B6
12	92	72.54	6480	2.2	KAF 37 ESQ 63B6
13	88	106.38	6500	2.3	
14	81	97.81	6530	2.5	
16	70	83.69	6570	2.9	
19	60	72.54	6800	3.3	
20	56	67.80	6610	3.5	
24	49	58.60	6430	4.1	
28	41	49.79	6130	4.8	
31	37	44.46	5930	5.4	K 37 ESQ 63A4
36	32	37.97	5660	6.3	KF 37 ESQ 63A4
39	30	35.57	5550	6.8	KA 37 ESQ 63A4
46	25	29.96	5270	8.0	KAF 37 ESQ 63A4
48	24	28.83	5210	8.4	
55	21	24.99	4980	9.6	
59	19	23.36	4880	10	
68	17	20.19	4660	11	
80	14	17.15	4430	13	
90	13	15.31	4280	14	
105	11	13.08	4070	15	
114	10	12.14	3970	16	
0.18 кВт					
0.09	16300	14975	73200	0.80	
0.11	13400	12440	79000	0.95	
0.12	11600	10915	79900	1.10	
0.13	10500	9819	80400	1.25	
0.16	8850	8443	81100	1.45	K 127 R77 ESQ 63B4
0.18	8040	7482	81400	1.60	KF 127 R77 ESQ 63B4
0.20	6990	6565	81800	1.85	KA 127 R77 ESQ 63B4
0.23	5940	5804	82100	2.2	KAF 127 R77 ESQ 63B4
0.26	5220	5027	82300	2.5	
0.30	4530	4423	82400	2.9	
0.34	3960	3889	82500	3.3	
0.40	3310	3311	82600	3.9	
0.16	8990	8328	65000	0.90	
0.18	7850	7270	65000	1.00	
0.21	6420	6184	65000	1.25	
0.23	5760	5662	65000	1.40	K 107 R77 ESQ 63B4
0.26	5230	5138	65000	1.55	KF 107 R77 ESQ 63B4
0.30	4570	4359	65000	1.75	KA 107 R77 ESQ 63B4
0.35	4000	3810	65000	2.0	KAF 107 R77 ESQ 63B4
0.39	3440	3358	65000	2.3	
0.44	3090	2977	65000	2.6	
0.51	2700	2599	65000	3.0	
0.58	2340	2286	65000	3.4	
0.28	4960	4669	39900	0.85	K 97 R57 ESQ 63B4
0.32	4390	4282	40000	1.00	KF 97 R57 ESQ 63B4
0.37	3860	3583	40000	1.10	KA 97 R57 ESQ 63B4
0.42	3370	3108	40000	1.25	KAF 97 R57 ESQ 63B4
0.48	2910	2757	40000	1.50	
0.55	2640	2419	40000	1.65	
0.62	2290	2123	40000	1.90	
0.71	2030	1856	40000	2.1	
0.81	1710	1625	40000	2.5	
0.92	1490	1430	40000	2.9	K 97 R57 ESQ 63B4
1.0	1380	1261	40000	3.1	KF 97 R57 ESQ 63B4
1.2	1210	1102	40000	3.6	KA 97 R57 ESQ 63B4
1.4	1040	957	40000	4.1	KAF 97 R57 ESQ 63B4
1.5	930	855	40000	4.6	
1.8	755	743	40000	5.7	
2.0	675	652	40000	6.4	
0.42	3330	3107	26400	0.80	K 87 R57 ESQ 63B4
0.48	2880	3728	27100	0.95	KF 87 R57 ESQ 63B4
0.56	2520	2371	27500	1.05	KA 87 R57 ESQ 63B4
					KAF 87 R57 ESQ 63B4

n2 [1/мин]	M [H*М]	i	Fr2 [N]	fs	Редуктор + РАМ
0.63	2290	2088	27800	1.20	
0.71	2030	1854	28000	1.35	
0.80	1820	1857	28200	1.50	K 87 R57 ESQ 63B4
0.93	1540	1415	28400	1.75	KF 87 R57 ESQ 63B4
1.1	1340	1228	28600	2.0	KA 87 R57 ESQ 63B4
1.2	1160	1078	28700	2.3	KAF 87 R57 ESQ 63B4
1.4	1000	951	28800	2.7	
1.6	870	837	28800	3.1	
1.8	755	728	28900	3.6	
0.87	1670	1514	14500	0.95	
0.95	1530	1388	15500	1.00	
1.1	1340	1218	16700	1.15	
1.2	1170	1053	17600	1.34	
1.4	1030	824	18200	1.50	K 77 R37 ESQ 63B4
1.6	910	815	18700	1.70	KF 77 R37 ESQ 63B4
1.9	750	709	19100	2.1	KA 77 R37 ESQ 63B4
2.1	655	622	19400	2.4	KAF 77 R37 ESQ 63B4
2.4	590	552	19500	2.6	
2.7	515	485	19700	3.0	
3.1	455	428	19800	3.4	
3.6	400	367	19900	3.9	
1.5	980	903	5660	0.85	
1.7	890	793	9620	0.90	
1.9	745	697	10900	1.10	
2.2	655	613	11600	1.25	K 67 R37 ESQ 63B4
2.4	580	542	12000	1.40	KF 67 R37 ESQ 63B4
2.8	520	471	12300	1.60	KA 67 R37 ESQ 63B4
3.2	445	420	12600	1.85	KAF 67 R37 ESQ 63B4
3.7	395	361	12800	2.1	
4.1	350	323	13000	2.3	
4.7	295	279	13000	2.8	
2.2	660	615	5580	0.90	
2.4	580	544	7800	1.05	
2.8	515	473	8300	1.15	
3.1	450	421	8870	1.35	K 57 R37 ESQ 63B4
3.6	395	362	8800	1.50	KF 57 R37 ESQ 63B4
4.1	350	319	8100	1.75	KA 57 R37 ESQ 63B4
4.7	300	280	9290	2.0	KAF 57 R37 ESQ 63B4
5.4	260	218	9420	2.3	
6.1	230	215	9540	2.6	
6.9	205	182	9810	2.9	
7.9	178	166	9700	3.4	
3.5	400	375	5930	1.00	
4.0	360	327	6440	1.10	
4.6	315	289	6920	1.25	K 47 R37 ESQ 63B4
5.2	275	256	7290	1.45	KF 47 R37 ESQ 63B4
5.9	245	225	7500	1.65	KA 47 R37 ESQ 63B4
6.7	210	198	7710	1.90	KAF 47 R37 ESQ 63B4
7.7	183	171	7860	2.2	
8.6	164	153	7950	2.4	
10	142	131	8040	2.8	
6.4	225	205	5300	0.90	K 37 R17 ESQ 63B4
7.3	199	181	5650	1.00	KF 37 R17 ESQ 63B4
8.2	175	160	5900	1.15	KA 37 R17 ESQ 63B4
9.7	148	138	6410	1.35	KAF 37 R17 ESQ 63B4
10	140	127	6200	1.45	
6.0	285	144.79	13000	2.9	K 67 D63L6
7.0	245	123.54	13000	3.4	KF 67 D63L6
8.1	215	108.03	13000	3.8	KA 67 D63L6
8.5	205	102.62	13000	4.0	KAF 67 D63L6
9.1	189	144.79	13000	4.3	K 67 ESQ 63B4
11	161	123.54	13000	5.1	KF 67 ESQ 63B4
					KA 67 ESQ 63B4
12	141	108.03	13000	5.8	KAF 67 ESQ 63B4

Каталог конических мотор-редукторов

n2 [1/мин]	M [Н*м]	i	Fr2 [N]	fs	Редуктор + ПАМ	
6.0	285	145.14	9340	2.1	K 57 D63L6	
7.0	245	123.85	9480	2.5		
8.0	215	108.29	9590	2.8		
8.5	205	102.88	9620	3.0		
9.6	178	90.28	9700	3.4		
9.1	189	145.14	9670	3.2		
11	161	123.85	9750	3.7		K 57 ESQ 63B4
12	141	108.29	9810	4.3		
13	134	102.88	9830	4.5		
15	118	90.26	9880	5.1		
17	100	76.56	9920	6.0		
6.6	260	131.87	7380	1.55	K 47 D63L6	
7.2	240	121.48	7530	1.65		
8.3	205	104.37	7740	1.95		
9.6	180	90.86	7880	2.2		
10	168	85.12	7930	2.4		
10	172	131.87	7910	2.3		K 47 ESQ 63B4
11	158	121.48	7910	2.5		
13	136	104.37	8080	2.9		
15	118	90.86	8120	3.4		
16	111	85.12	8140	3.8		
8.2	210	106.38	5520	0.95	K 37 D63L6	
8.9	193	97.81	5710	1.05		
10	165	83.69	5990	1.20		
12	143	72.54	6170	1.40		
12	139	106.38	6210	1.45		
14	127	97.81	6280	1.55		
16	109	83.69	6400	1.65		
18	95	72.54	6470	2.1		
19	88	67.80	6500	2.3		
23	76	58.60	6280	2.6		
27	65	49.79	6010	3.1		
30	58	44.46	5830	3.5		
35	49	37.97	5580	4.1		
37	46	35.57	5480	4.3	K 37 ESQ 63B4	
44	39	29.96	5220	5.1		
46	38	28.83	5180	5.3		
53	33	24.99	4950	6.2		
57	30	23.36	4850	6.4		
65	26	20.19	4650	7.0		
77	22	17.15	4430	8.1		
86	20	15.31	4280	8.8		
101	17	13.08	4080	9.7		
109	16	12.14	3980	10		
126	14	10.49	3810	12		
148	12	8.91	3620	14		
166	10	7.96	3490	15		
0.13	15300	9819	75300	0.85	K 137 R77 ESQ 63D4	
0.15	13000	8443	79200	1.00		
0.17	11700	7482	79900	1.10		
0.20	10200	6585	80600	1.30		
0.22	8770	5804	81200	1.50		
0.26	7670	5027	81600	1.70		
0.29	6680	4423	81900	1.95		
0.33	5850	3889	82100	2.2		
0.39	4930	3311	82300	2.6		

n2 [1/мин]	M [Н*м]	i	Fr2 [N]	fs	Редуктор + ПАМ	
0.25 кВт						
0.21	9440	6184	65000	0.85	K 107 R77 ESQ 63D4	
0.23	8520	5662	65000	0.95		
0.25	7730	5136	65000	1.05		
0.30	6700	4369	65000	1.20		
0.34	5850	3810	65000	1.35		
0.39	5070	3358	65000	1.60		
0.44	4540	2977	65000	1.75		
0.50	3970	2599	65000	2.0		
0.57	3450	2286	65000	2.3		
0.67	2930	1936	65000	2.7		
0.76	2640	1713	65000	3.0	K 107 R77 ESQ 63D4	
0.84	2390	1554	65000	3.3		
0.97	2060	1336	65000	3.9		
0.42	4890	3180	40000	0.90		K 97 57 ESQ 63D4
0.47	4250	2757	40000	1.00		
0.54	3840	2419	40000	1.10		
0.61	3340	2123	40000	1.30		
0.70	2950	1856	40000	1.45		
0.80	2520	1625	40000	1.70		
0.91	2190	1430	40000	1.95		
1.0	2010	1261	40000	2.1		
1.2	1750	1102	40000	2.5		
1.4	1520	957	40000	2.8		
1.5	1360	855	40000	3.2		
0.62	3320	2088	26400	0.80	K 87 R57 ESQ 63D4	
0.70	2950	1854	27000	0.90		
0.78	2640	1657	27400	1.00		
0.92	2250	1415	27800	1.20		
1.1	1950	1229	28100	1.40		
1.2	1700	1078	28300	1.60		
1.4	1470	951	28500	1.85		
1.5	1280	837	28800	2.1		
1.8	1110	726	28700	2.4		
2.0	990	638	28800	2.7		
1.2	1690	1053	14300	0.90	K 77 R37 ESQ 63D4	
1.4	1480	924	15800	1.05		
1.6	1310	815	16900	1.20		
1.8	1100	709	17900	1.40		
2.1	960	622	18400	1.60		
2.3	860	552	18000	1.80		
2.7	755	485	19100	2.0		
3.0	665	428	19500	2.3		
3.5	580	367	19700	2.7		
4.0	515	328	19800	3.0		
4.5	460	290	19900	3.4		
5.2	395	252	19900	3.9		
5.9	345	221	19900	4.5		
6.7	305	195	20000	5.1		
7.4	270	175	20000	5.7		
2.1	960	613	7350	0.85	K 67 R37 ESQ 63D4	
2.4	850	542	10100	0.95		
2.8	755	471	10900	1.10		
3.1	655	420	11600	1.25		
3.6	575	361	12000	1.45		
4.0	510	323	12400	1.60		
4.7	435	279	12700	1.90		
5.3	385	246	12900	2.1		
6.0	335	217	1300	2.4		

n2 [1/мин]	M [H*М]	i	Fr2 [N]	fs	Редуктор + ПАМ
3.1	655	421	5750	0.90	
3.6	575	362	7840	1.05	
4.1	505	319	8380	1.20	
4.7	435	280	8720	1.35	
5.3	385	246	8950	1.55	K 57 R77 ESQ 63D4
6.1	335	215	8150	1.80	KF 57 R77 ESQ 63D4
6.8	300	192	9150	2.0	KA 57 R77 ESQ 63D4
7.8	260	166	9280	2.3	KAF107 R77 ESQ 63D4
9.0	225	145	9550	2.7	
10	205	129	9620	2.9	
12	173	111	9720	3.5	
13	152	97	9780	4.0	
4.4	540	154.02	19600	2.9	K 77 ESQ 80B8
5.0	475	135.28	19700	3.3	KF 77 ESQ 80B8
5.3	450	128.52	19800	3.4	KA 77 ESQ 80B8
6.0	400	113.56	19900	3.9	KAF 77 ESQ 80B8
4.6	520	192.18	19700	2.8	K 77 ESQ 71B6
4.9	485	179.37	19700	3.0	KF 77 ESQ 71B6
5.7	420	154.02	19800	3.7	KA 77 ESQ 71B6
6.5	365	135.28	19900	4.2	KAF 77 ESQ 71B6
5.5	435	123.54	12700	1.90	K 67 ESQ 80B8
6.3	380	108.03	12900	2.2	KF 67 ESQ 80B8
6.6	360	102.62	12900	2.3	KA 67 ESQ 80B8
7.6	315	90.4	13000	2.8	KAF 67 ESQ 80B8
6.1	395	144.79	12800	2.1	K 67 ESQ 71B6
7.1	335	123.54	13000	2.5	KF 67 ESQ 71B6
8.1	395	108.03	13000	2.8	KA 67 ESQ 71B6
8.6	280	102.62	13000	3.0	KAF 67 ESQ 71B6
9.0	265	144.79	13000	3.1	K 67 ESQ 63D4
11	225	123.54	13000	3.6	KF 67 ESQ 63D4
12	198	108.03	13000	4.1	KA 67 ESQ 63D4
13	189	102.62	13000	4.3	KAF 67 ESQ 63D4
6.1	395	145.14	8910	1.50	
7.1	335	123.85	9150	1.80	K 57 ESQ 71B6
8.1	295	108.29	9310	2.0	KF 57 ESQ 71B6
8.6	280	102.88	9360	2.2	KA 57 ESQ 71B6
9.8	245	90.26	9480	2.5	KAF 57 ESQ 71B6
11	210	76.56	9610	2.9	
9.0	265	145.14	9410	2.2	
11	225	123.85	9540	2.6	K 57 ESQ 63D4
12	199	108.28	9640	3.0	KF 57 ESQ 63D4
13	189	102.88	9670	3.2	KA 57 ESQ 63D4
14	166	90.26	9740	3.6	KAF57 ESQ 63D4
17	141	76.56	9810	4.3	
6.7	360	131.87	6470	1.10	K 47 ESQ 71B6
7.2	330	121.48	6780	1.20	KF 47 ESQ 71B6
8.4	285	104.37	7210	1.40	KA 47 ESQ 71B6
9.7	245	90.86	7280	1.60	KAF 47 ESQ 71B6
10	230	85.12	7590	1.75	
9.9	240	131.87	7510	1.65	K 47 ESQ 63D4
11	225	121.48	7640	1.80	KF 47 ESQ 63D4
12	192	104.37	7820	2.1	KA 47 ESQ 63D4
14	167	90.86	7930	2.4	KAF 47 ESQ 63D4
15	156	85.12	7980	2.6	
11	225	83.69	5300	0.90	K 37 ESQ 71B6
12	197	72.54	5680	1.00	KF 37 ESQ 71B6
13	184	67.80	5810	1.10	KA 37 ESQ 71B6
15	159	58.60	6050	1.25	KAF 37 ESQ 71B6
18	135	49.79	6230	1.50	

n2 [1/мин]	M [H*М]	i	Fr2 [N]	fs	Редуктор + ПАМ
12	195	106.38	5690	1.00	
13	180	97.81	5860	1.10	
16	154	83.69	6090	1.30	
18	133	72.54	6250	1.50	
19	125	67.80	6230	1.60	
22	108	58.60	6030	1.85	
26	91	48.79	5810	2.2	
29	820	44.46	5850	2.5	
34	70	37.97	5430	2.9	
37	65	35.57	5340	3.1	
43	55	29.96	5100	3.6	K 37 ESQ 63D4
45	53	28.83	5050	3.8	KF 37 ESQ 63D4
52	46	24.99	4860	4.4	KA 37 ESQ 63D4
56	43	23.36	4770	4.6	KAF37 ESQ 63D4
64	37	20.19	4580	5.0	
76	32	17.15	4370	5.7	
85	28	15.31	4230	6.2	
99	24	13.08	4030	6.9	
107	22	12.14	3940	7.2	
124	19	10.49	3780	8.3	
146	16	8.91	3590	9.8	
163	15	7.89	3470	11	
191	13	6.80	3310	12	
204	12	6.37	3240	12	
0.37кВт					
0.18	16600	7482	72600	0.80	
0.21	14500	6585	76900	0.90	
0.24	12600	5804	79400	1.05	K 127 R77 ESQ 71B4
0.27	11000	5027	80200	1.20	KF 127 R77 ESQ 71B4
0.31	9610	4423	80800	1.35	KA 127 R77 ESQ 71B4
0.35	8430	3889	81300	1.55	KAF 127 R77 ESQ 71B4
0.42	7120	3311	81700	1.85	
0.72	4230	1928	82500	3.1	K 127 R77 ESQ 71B4
0.79	3860	1757	82500	3.4	KF 127 R77 ESQ 71B4
0.90	3360	1541	82600	3.9	KA 127 R77 ESQ 71B4
0.36	8380	3710	65000	0.95	
0.41	7300	3358	65000	1.10	K 107 R77 ESQ 71B4
0.46	6510	2977	65000	1.25	KF 107 R77 ESQ 71B4
0.53	5690	2599	65000	1.40	KA 107 R77 ESQ 71B4
0.60	4970	2286	65000	1.60	KAF 107 R77 ESQ 71B4
0.71	4210	1939	65000	1.90	
0.81	3790	1713	65000	2.1	K 107 R77 ESQ 71B4
0.89	3440	1554	65000	2.3	KF 107 R77 ESQ 71B4
1.0	2950	1336	65000	2.7	KA 107 R77 ESQ 71B4
1.2	2580	1166	65000	3.1	KAF 107 R77 ESQ 71B4
0.65	4770	2123	40000	0.90	
0.74	4200	1856	40000	1.00	
0.85	3610	1825	40000	1.20	
0.96	3160	1430	40000	1.35	K 97 R57 ESQ 71B4
1.1	2850	1261	40000	1.50	KF 97 R57 ESQ 71B4
1.2	2490	1102	40000	1.70	KA 97 R57 ESQ 71B4
1.4	2160	957	40000	2.0	KAF 97 R57 ESQ 71B4
1.6	1930	855	40000	2.2	
1.9	1620	743	40000	2.7	
2.1	1430	652	40000	3.0	
2.4	1280	573	40000	3.4	
0.97	3200	1415	26600	0.85	
1.1	2770	1229	27200	0.95	
1.3	2420	1078	27600	1.10	
1.5	2110	951	27900	1.30	
1.6	1850	837	28200	1.45	K 87 R57 ESQ 71B4
1.9	1600	726	28400	1.70	KF 87 R57 ESQ 71B4
2.2	1420	638	28500	1.90	KA 87 R57 ESQ 71B4
2.5	1240	562	28600	2.2	KAF 87 R57 ESQ 71B4
2.9	1040	474	28800	2.6	
3.2	940	428	28800	2.9	
3.7	810	373	28900	3.3	

Каталог конических мотор-редукторов

n2 [1/мин]	M [Н*м]	i	Fr2 [N]	fs	Редуктор + ПАМ
1.7	1860	815	10600	0.85	
2.0	1580	709	15200	1.00	
2.2	1380	622	16500	1.10	
2.5	1230	552	17300	1.25	
2.8	1080	485	18000	1.45	
3.2	950	428	18500	1.60	K 77 R37 ESQ 71B4
3.8	830	367	18900	1.85	KF 77 R37 ESQ 71B4
4.2	735	328	19200	2.1	KA 77 R37 ESQ 71B4
4.8	655	290	19400	2.4	KAF 77 R37 ESQ 71B4
5.5	565	252	19800	2.8	
6.2	495	221	19700	3.1	
7.1	435	195	19800	3.5	
7.9	390	175	19900	4.0	
9.0	340	154	19900	4.5	
3.3	940	420	9000	0.90	
3.8	820	361	10300	1.00	
4.3	725	323	11100	1.15	
4.9	625	279	11800	1.30	K 67 R37 ESQ 71B4
5.6	550	246	12200	1.50	KF 67 R37 ESQ 71B4
6.3	485	217	12500	1.70	KA 67 R37 ESQ 71B4
7.2	430	191	12700	1.90	KAF 67 R37 ESQ 71B4
8.3	370	166	12900	2.2	
9.6	320	144	13000	2.5	
11	275	122	13000	3.0	
4.9	625	280	7430	0.95	
5.6	550	246	8040	1.10	
6.4	480	215	8520	1.25	K 57 R37 ESQ 71B4
7.2	430	192	8750	1.40	KF 57 R37 ESQ 71B4
8.3	370	166	9000	1.60	KA 57 R37 ESQ 71B4
9.6	325	145	9200	1.85	KAF 57 R37 ESQ 71B4
11	290	129	9320	2.1	
12	245	111	9480	2.4	
14	215	97	9580	2.8	
3.9	910	174.19	28800	3.0	K 87 ESQ 90S8
4.1	850	164.34	28900	3.2	KF 87 ESQ 90S8
4.6	765	147.32	28900	3.5	KA 87 ESQ 90S8
4.6	775	197.37	28900	3.5	KAF 87 ESQ 90S8
5.2	685	174.19	28900	4.0	K 87 ESQ 80A6
5.0	705	135.28	19300	2.2	KF 87 ESQ 80A6
5.3	670	128.52	19300	2.3	KA 87 ESQ 80A6
6.0	590	113.56	19500	2.6	KAF 87 ESQ 80A6
7.0	505	97.05	19700	3.1	K 77 ESQ 90S8
5.8	605	154.02	19500	2.6	KF 77 ESQ 90S8
6.7	530	135.28	19600	2.9	KA 77 ESQ 90S8
7.0	505	128.52	19700	3.1	KAF 77 ESQ 90S8
7.9	445	113.56	19800	3.5	K 77 ESQ 80A6
7.2	490	192.18	19700	3.0	KF 77 ESQ 80A6
7.7	460	179.37	19800	3.2	KA 77 ESQ 80A6
9.0	395	154.02	19900	3.9	KAF 77 ESQ 80A6
6.3	560	108.03	12100	1.45	K 67 ESQ 90S8
6.6	535	102.62	12300	1.55	KF 67 ESQ 90S8
7.6	470	90.04	12600	1.75	KA 67 ESQ 90S8
7.3	485	123.54	12500	1.70	KAF 67 ESQ 90S8
8.3	425	108.03	12700	1.95	K 67 ESQ 80A6
8.8	405	102.62	12800	2.0	KF 67 ESQ 80A6
10	355	90.04	13000	2.3	KA 67 ESQ 80A6
9.5	370	144.79	12900	2.2	KAF 67 ESQ 80A6
11	315	123.54	13000	2.6	K 67 ESQ 71B4
13	275	108.03	13000	3.0	KF 67 ESQ 71B4
15	230	90.04	13000	3.6	KA 67 ESQ 71B4
18	196	76.37	13000	4.2	KAF 67 ESQ 71B4

n2 [1/мин]	M [Н*м]	i	Fr2 [N]	fs	Редуктор + ПАМ
7.3	485	123.85	8490	1.25	
8.3	425	108.29	8770	1.40	K 57 ESQ 80A6
8.8	405	102.88	8870	1.50	KF 57 ESQ 80A6
10	355	90.28	9070	1.70	KA 57 ESQ 80A6
12	300	76.56	8280	2.0	KAF 57 ESQ 80A6
13	270	69.12	9390	2.2	
9.5	370	145.14	9000	1.60	
11	315	123.85	9220	1.90	K 57 ESQ 71B4
13	275	108.29	9370	2.2	KF 57 ESQ 71B4
13	265	102.88	9420	2.3	KA 57 ESQ 71B4
15	230	90.26	9530	2.6	KAF 57 ESQ 71B4
18	196	76.56	9650	3.1	
20	177	69.12	9700	3.4	
8.6	410	104.37	5490	1.00	K 47 ESQ 80A6
9.9	355	90.86	6480	1.10	KF 47 ESQ 80A6
11	335	85.12	6730	1.20	KA 47 ESQ 80A6
12	295	75.20	7100	1.35	KAF 47 ESQ 80A6
10	340	131.87	6680	1.20	K 47 ESQ 71B4
11	310	121.48	6980	1.30	KF 47 ESQ 71B4
13	265	104.37	7330	1.50	KA 47 ESQ 71B4
15	235	90.86	7580	1.70	KAF 47 ESQ 71B4
16	220	85.12	7670	1.85	
18	193	75.20	7810	2.1	K 47 ESQ 71B4
20	179	69.84	7880	2.2	KF 47 ESQ 71B4
22	162	63.30	7980	2.5	KA 47 ESQ 71B4
14	250	97.81	2520	0.80	
16	215	83.69	5470	0.95	
19	186	72.54	5690	1.10	
20	174	67.80	5630	1.15	
24	150	58.60	5510	1.35	
28	128	49.79	5350	1.55	
31	114	44.46	5230	1.75	
36	97	37.97	5060	2.1	
39	91	35.57	4990	2.2	
46	77	29.96	4800	2.6	
48	74	28.83	4750	2.7	K 37 ESQ 71B4
55	64	24.99	4590	3.1	KF 37 ESQ 71B4
59	60	23.36	4510	3.3	KA 37 ESQ 71B4
68	52	20.19	4350	3.6	KAF 37 ESQ 71B4
80	44	17.15	4160	4.1	
90	39	15.31	4040	4.5	
105	34	13.08	3880	4.9	
114	31	12.14	3780	5.1	
132	27	10.49	3630	5.9	
155	23	8.91	3460	7.0	
173	20	7.96	3350	7.6	
203	17	6.80	3190	8.6	
217	16	6.37	3130	8.9	
257	14	5.36	2970	10	
0.55 кВт					
0.08	55900	16978	179800	0.90	
0.10	46500	14272	190000	1.10	
0.10	42500	13116	190000	1.20	K 187 R97 ESQ 80A4
0.12	37400	11647	190000	1.35	
0.19	23900	7343	190000	2.1	
0.12	38400	11573	150000	0.85	
0.13	33800	10264	150000	0.95	
0.16	28100	8628	150000	1.15	K 167 R97 ESQ 80A4
0.21	21400	6562	150000	1.50	
0.25	17200	5355	150000	1.85	
0.33	13200	4079	150000	2.4	

n2 [1/мин]	M [H*м]	i	Fr2 [N]	fs	Редуктор + РАМ
0.20	22400	6881	109700	0.80	K 157 R97 ESQ 80A4
0.23	19300	5931	111500	0.95	KF 157 R97 ESQ 80A4
0.34	13000	3979	114400	1.40	KA 157 R97 ESQ 80A4
0.45	9940	3051	115300	1.80	KAF 157 R97 ESQ 80A4
0.31	14900	4423	76200	0.85	K 127 R77 ESQ 80A4
0.35	13000	3889	79200	1.00	KF 127 R77 ESQ 80A4
0.41	11100	3311	80200	1.20	KA 127 R77 ESQ 80A4
0.45	10000	3009	80700	1.30	KAF 127 R77 ESQ 80A4
0.52	8830	2607	81200	1.50	
0.71	6560	1926	81900	2.0	
0.77	5980	1757	82100	2.2	K 127 R77 ESQ 80A4
0.88	5220	1541	82300	2.5	KF 127 R77 ESQ 80A4
1.0	4570	1342	82400	2.8	KA 127 R77 ESQ 80A4
1.2	3990	1177	82500	3.3	KAF 127 R77 ESQ 80A4
1.3	3490	1025	82500	3.7	
0.46	10100	2977	65000	0.80	K 107 R77 ESQ 80A4
0.52	8770	2599	65000	0.90	KF 107 R77 ESQ 80A4
0.59	7690	2288	65000	1.05	KA 107 R77 ESQ 80A4
0.70	6520	1939	65000	1.25	KAF 107 R77 ESQ 80A4
0.79	5850	1713	65000	1.35	
0.87	5310	1554	65000	1.50	
1.0	4570	1336	65000	1.75	K 107 R77 ESQ 80A4
1.2	3990	1166	65000	2.0	KF 107 R77 ESQ 80A4
1.3	3450	1030	65000	2.3	KA 107 R77 ESQ 80A4
1.5	3000	904	65000	2.7	KAF 107 R77 ESQ 80A4
1.7	2700	793	65000	3.0	
2.0	2360	696	65000	3.4	
2.2	2050	615	65000	3.9	
0.95	4880	1430	40000	0.90	
1.1	4380	1261	40000	1.00	
1.2	3820	1102	40000	1.15	
1.4	3320	857	40000	1.30	
1.6	2960	655	40000	1.45	K 97 R57 ESQ 80A4
1.8	2520	743	40000	1.70	KF 97 R57 ESQ 80A4
2.1	2200	652	40000	1.95	KA 97 R57 ESQ 80A4
2.4	1970	573	40000	2.2	KAF 97 R57 ESQ 80A4
2.7	1700	504	40000	2.5	
3.1	1470	437	40000	2.9	
3.6	1300	382	40000	3.3	
4.5	1040	305	40000	4.1	
1.4	3260	951	28500	0.85	
1.6	2860	837	27100	0.95	
1.9	2480	726	27600	1.10	
2.1	2190	638	27900	1.25	
2.4	1920	562	28100	1.40	K 87 R57 ESQ 80A4
2.9	1620	474	28400	1.65	KF 87 R57 ESQ 80A4
3.2	1450	426	28500	1.85	KA 87 R57 ESQ 80A4
3.7	1260	373	28600	2.1	KAF 87 R57 ESQ 80A4
4.1	1100	330	28700	2.4	
4.6	990	294	28800	2.7	
5.4	850	250	28900	3.2	
5.8	800	236	28900	3.4	
6.8	680	201	28900	4.0	
2.5	1900	552	5780	0.80	
2.8	1670	485	14500	0.95	
3.2	1470	428	15900	1.05	
3.7	1270	367	17100	1.20	K 77 R37 ESQ 80A4
4.2	1130	328	17800	1.35	KF 77 R37 ESQ 80A4
4.7	1000	290	18300	1.55	KA 77 R37 ESQ 80A4
5.4	870	252	18800	1.80	KAF 77 R37 ESQ 80A4
6.2	760	221	19100	2.0	
7.0	670	195	19300	2.3	
7.8	600	175	19500	2.6	
8.8	530	154	19600	2.9	

n2 [1/мин]	M [H*м]	i	Fr2 [N]	fs	Редуктор + РАМ
4.9	960	279	7360	0.85	
5.5	840	246	10100	0.95	K 67 R37 ESQ 80A4
6.2	745	217	10900	1.10	KF 67 R37 ESQ 80A4
7.1	660	191	11500	1.25	KA 67 R37 ESQ 80A4
8.2	570	166	12100	1.45	KAF 67 R37 ESQ 80A4
9.4	495	144	12400	1.65	
11	420	122	12700	1.95	
7.1	660	192	5180	0.90	
8.2	575	166	7850	1.05	K 57 R37 ESQ 80A4
9.4	495	145	8430	1.20	KF 57 R37 ESQ 80A4
11	445	129	8680	1.35	KA 57 R37 ESQ 80A4
12	380	111	8970	1.60	KAF 57 R37 ESQ 80A4
14	335	97	9150	1.80	
3.9	1350	174.19	28800	2.0	K 87 ESQ 90L8
4.1	1270	164.34	28600	2.1	KF 87 ESQ 90L8
4.6	1140	147.32	28700	2.4	KA 87 ESQ 90L8
4.6	1150	197.37	28700	2.3	KAF 87 ESQ 90L8
5.2	1020	174.19	28800	2.7	K 87 ESQ 80B6
5.5	960	164.34	28800	2.8	KF 87 ESQ 80B6
6.1	860	147.32	28900	3.1	KA 87 ESQ 80B6
5.0	1040	135.28	18100	1.50	K 77 ESQ 90L8
5.3	990	128.52	18300	1.55	KF 77 ESQ 90L8
6.0	880	113.56	18700	1.75	KA 77 ESQ 90L8
7.0	750	97.05	19100	2.1	KAF 77 ESQ 90L8
5.8	900	154.02	18700	1.70	K 77 ESQ 80B6
6.7	790	135.28	19000	1.95	KF 77 ESQ 80B6
7.0	750	128.52	19100	2.1	KA 77 ESQ 80B6
7.9	665	113.56	19400	2.3	KAF 77 ESQ 80B6
8.8	595	154.02	19500	2.6	K 77 ESQ 80A4
10	520	135.28	19700	3.0	KF 77 ESQ 80A4
11	495	128.52	19700	3.1	KA 77 ESQ 80A4
12	440	113.58	19800	3.5	KAF 77 ESQ 80A4
14	375	97.05	19900	4.1	
7.3	720	123.54	11100	1.15	K 67 ESQ 80B6
8.3	630	108.03	11700	1.30	KF 67 ESQ 80B6
8.8	600	102.62	11900	1.35	KA 67 ESQ 80B6
10	525	90.04	12300	1.55	KAF 67 ESQ 80B6
12	445	76.37	12600	1.85	
11	475	123.54	12500	1.70	K 67 ESQ 80A4
13	415	108.03	12800	1.95	KF 67 ESQ 80A4
15	350	90.04	13000	2.4	KA 67 ESQ 80A4
18	295	76.37	13000	2.8	KAF 67 ESQ 80A4
8.3	630	108.29	7360	0.95	
8.8	600	102.88	7630	1.00	K 57 ESQ 80B6
10	525	90.26	8220	1.15	KF 57 ESQ 80B6
12	445	76.56	8670	1.35	KA 57 ESQ 80B6
13	405	69.12	8870	1.50	KAF 57 ESQ 80B6
15	355	60.81	9070	1.70	
16	335	57.42	9150	1.80	
11	480	123.85	8520	1.25	
13	420	108.29	8800	1.45	
13	395	102.88	8890	1.50	K 57 ESQ 80A4
15	350	90.26	9100	1.70	KF 57 ESQ 80A4
18	295	76.56	9300	2.0	KA 57 ESQ 80A4
20	265	69.12	9410	2.2	KAF 57 ESQ 80A4
22	235	60.81	9520	2.6	
24	220	57.42	9560	2.7	
13	405	104.37	5880	1.00	K 47 ESQ 80A4
15	350	90.86	6550	1.15	KF 47 ESQ 80A4
16	330	85.12	6790	1.20	KA 47 ESQ 80A4
18	290	75.20	7150	1.40	KAF 47 ESQ 80A4
19	270	69.84	7310	1.50	

Каталог конических мотор-редукторов

n2 [1/мин]	M [Н*м]	i	Fr2 [N]	fs	Редуктор + ПАМ
21	245	63.30	7500	1.65	K 47 ESQ 80A4
24	220	56.83	7600	1.80	KF 47 ESQ 80A4
28	189	48.95	7830	2.1	KA 47 ESQ 80A4
30	178	46.03	7880	2.2	KAF 47 ESQ 80A4
23	225	58.60	4850	0.90	
27	192	49.79	4790	1.05	
31	172	44.46	4740	1.15	
36	147	37.97	4840	1.35	
38	137	35.57	4600	1.45	
45	116	29.96	4470	1.75	
47	111	28.83	4440	1.80	
54	97	24.99	4320	2.1	
58	90	23.36	4260	2.2	K 37 ESQ 80A4
67	78	20.19	4130	2.4	KF 37 ESQ 80A4
79	66	17.15	3980	2.7	KA 37 ESQ 80A4
89	59	15.31	3880	3.0	KAF 37 ESQ 80A4
104	51	13.08	3730	3.3	
112	47	12.14	3660	3.4	
130	41	10.49	3520	4.0	
153	34	8.91	3370	4.7	
171	31	7.96	3270	5.1	
200	26	6.80	3130	5.7	
214	25	6.37	3070	5.9	
254	21	5.36	2920	6.8	
0.75кВт					
0.11	58400	13116	175300	0.85	
0.12	51500	11847	187300	0.95	
0.19	32800	7343	190000	1.50	K 187 R97 ESQ 80B4
1.20	30000	6747	190000	1.65	
0.23	28500	5991	190000	1.90	
0.16	38600	8628	150000	0.85	
0.21	29300	6562	150000	1.10	
0.26	23700	5355	150000	1.35	K 167 R97 ESQ 80B4
0.34	16200	4079	150000	1.75	
0.41	15100	3376	150000	2.1	
0.35	17300	3979	112300	1.00	K 157 R97 ESQ 80B4 KF 157 R97 ESQ 80B4 KA 157 R97 ESQ 80B4 KAF 157 R97 ESQ 80B4
0.45	13600	3051	114100	1.30	
0.83	7440	1659	115900	2.4	K 157 R97 ESQ 80B4 KF 157 R97 ESQ 80B4 KA 157 R97 ESQ 80B4 KAF 157 R97 ESQ 80B4
1.0	6040	1365	116200	3.0	
0.42	15100	3311	75800	0.85	K 127 R77 ESQ 80B4
0.46	13700	3009	78600	0.95	KF 127 R77 ESQ 80B4 KA 127 R77 ESQ 80B4 KAF 127 R77 ESQ 80B4
0.53	11800	2607	79800	1.10	
0.72	8930	1926	81100	1.45	
0.79	8150	1757	81400	1.60	
0.90	7120	1541	81700	1.85	K 127 R77 ESQ 80B4
1.0	6220	1342	82000	2.1	KF 127 R77 ESQ 80B4
1.2	5440	1177	82200	2.4	KA 127 R77 ESQ 80B4
1.4	4750	1025	82400	2.7	KAF 127 R77 ESQ 80B4
1.5	4150	899	82500	3.1	
0.81	7960	1713	65000	1.00	
0.89	7230	1554	65000	1.10	
1.0	6210	1336	65000	1.30	
1.2	5420	1166	65000	1.50	K 107 R77 ESQ 80B4
1.3	4710	1030	65000	1.70	KF 107 R77 ESQ 80B4
1.5	4120	904	65000	1.95	KA 107 R77 ESQ 80B4
1.7	3680	793	65000	2.2	KAF 107 R77 ESQ 80B4
2.0	3210	696	65000	2.5	
2.2	2800	615	65000	2.8	

n2 [1/мин]	M [Н*м]	i	Fr2 [N]	fs	Редуктор + ПАМ
1.2	5180	1102	39700	0.85	
1.4	4490	957	40000	0.95	
1.6	4020	855	40000	1.05	
1.9	3430	743	40000	1.25	
2.1	3020	652	40000	1.40	
2.4	2680	573	40000	1.60	K 97 R57 ESQ 80B4
2.7	2320	504	40000	1.85	KF 97 R57 ESQ 80B4
3.2	2010	437	40000	2.1	KA 97 R57 ESQ 80B4
3.6	1770	382	40000	2.4	KAF 97 R57 ESQ 80B4
4.5	1420	305	40000	3.0	
5.4	1190	258	40000	3.6	
5.9	1080	232	40000	4.0	
6.9	920	199	40000	4.7	
1.9	3370	726	26300	0.80	
2.2	2970	638	26900	0.90	
2.5	2610	562	27400	1.05	
2.9	2200	474	27900	1.25	K 87 R57 ESQ 80B4
3.2	1980	426	28100	1.35	KF 87 R57 ESQ 80B4
3.7	1720	373	28300	1.55	KA 87 R57 ESQ 80B4
4.2	1520	330	28500	1.80	KAF 87 R57 ESQ 80B4
4.7	1350	294	28800	2.0	
5.5	1160	250	28700	2.3	
5.8	1100	236	28700	2.5	
6.9	930	201	28800	2.9	
3.8	1720	367	14000	0.90	K 77 R37 ESQ 80B4
4.2	1540	328	15500	1.00	KF 77 R37 ESQ 80B4
4.8	1360	290	16600	1.15	KA 77 R37 ESQ 80B4
5.5	1180	252	17500	1.30	KAF 77 R37 ESQ 80B4
6.2	1030	221	18200	1.50	
3.9	1830	176.05	40000	2.3	K 97 ESQ 100LA8
4.5	1590	153.21	40000	2.7	KF 97 ESQ 100LA8
4.9	1460	140.28	40000	3.0	KA 97 ESQ 100LA8
					KAF 97 ESQ 100LA8
4.7	1530	147.32	28500	1.75	K 87 ESQ 100LA8
5.4	1320	126.91	28600	2.0	KF 87 ESQ 100LA8
6.0	1200	115.82	28700	2.2	KA 87 ESQ 100LA8
6.7	1070	102.71	28700	2.5	KAF 87 ESQ 100LA8
5.2	1390	174.19	28600	1.95	K 87 ESQ 90S6
5.5	1310	164.34	28600	2.1	KF 87 ESQ 90S6
6.1	1170	147.32	28700	2.3	KA 87 ESQ 90S6
7.1	1010	128.91	28800	2.7	KAF 87 ESQ 90S6
7.0	1020	197.37	28800	2.6	K 87 ESQ 80B4
7.9	900	174.19	28800	3.0	KF 87 ESQ 80B4
8.4	850	164.34	28900	3.2	KA 87 ESQ 80B4
9.4	765	147.32	28900	3.5	KAF 87 ESQ 80B4
6.7	1080	135.28	18000	1.45	K 77 ESQ 90S6
7.0	1020	128.52	18200	1.50	KF 77 ESQ 90S6
7.9	900	113.56	18700	1.70	KA 77 ESQ 90S6
9.3	770	97.05	19100	2.0	KAF 77 ESQ 90S6
10	710	88.97	19200	2.2	
9.0	800	154.05	19000	1.95	K 77 ESQ 80B4
10	700	135.28	19300	2.2	KF 77 ESQ 80B4
11	665	128.52	19300	2.3	KA 77 ESQ 80B4
12	590	113.56	19500	2.6	KAF 77 ESQ 80B4
14	505	97.05	19700	3.1	
11	640	123.54	11700	1.30	K 67 ESQ 80B4
13	560	108.08	12100	1.45	KF 67 ESQ 80B4
15	465	90.04	12600	1.75	KA 67 ESQ 80B4
					KAF 67 ESQ 80B4
18	395	76.37	12800	2.1	K 67 ESQ 80B4
20	360	68.95	13000	2.3	KF 67 ESQ 80B4
23	315	60.66	13000	2.6	KA 67 ESQ 80B4
24	295	57.28	13000	2.8	KAF 67 ESQ 80B4

n2 [1/мин]	M [Н*м]	i	Fr2 [N]	fs	Редуктор + РАМ
11	645	123.85	7130	0.95	
13	560	108.29	7940	1.05	
13	535	102.88	8160	1.10	
15	470	90.26	8570	1.30	K 57 ESQ 80B4
18	395	76.56	8890	1.50	KF 57 ESQ 80B4
20	360	69.12	9080	1.65	KA 57 ESQ 80B4
23	315	60.81	9230	1.90	KAF 57 ESQ 80B4
24	300	57.42	9230	2.0	
28	255	48.89	9450	2.4	
31	230	44.43	9530	2.6	
18	390	75.20	6060	1.00	K 47 ESQ 80B4
20	365	69.84	6410	1.10	KF 47 ESQ 80B4
22	330	63.30	6790	1.20	KA 47 ESQ 80B4
22	330	63.30	6790	1.20	KAF 47 ESQ 80B4
24	295	56.83	7110	1.35	
28	255	48.95	7430	1.55	K 47 ESQ 80B4
30	240	46.03	7540	1.65	KF 47 ESQ 80B4
35	205	39.61	7740	1.95	KA 47 ESQ 80B4
39	184	35.39	7780	2.2	KAF 47 ESQ 80B4
44	162	31.30	7550	2.5	
31	230	44.46	4170	0.85	
36	197	37.97	4150	1.00	
39	185	35.57	4140	1.10	
46	156	29.96	4080	1.30	
48	150	28.83	4060	1.35	
55	130	24.99	3990	1.55	
59	121	23.36	3950	1.60	
68	105	20.19	3860	1.75	K 37 ESQ 80B4
80	89	17.15	3750	2.0	KF 37 ESQ 80B4
90	80	15.31	3670	2.2	KA 37 ESQ 80B4
105	68	13.08	3550	2.4	KAF 37 ESQ 80B4
114	63	12.14	3550	2.5	
132	54	10.49	3380	2.9	
155	46	8.91	3250	3.5	
173	41	7.98	3180	3.8	
203	35	6.80	3030	4.2	
217	33	6.37	2980	4.4	
257	28	5.36	2840	5.0	
1.1 кВт					
0.15	60700	9363	171000	0.80	
0.17	52400	8126	185900	0.95	
0.19	48300	7343	190000	1.05	
0.21	44300	6747	190000	1.15	K 187 R97 ESQ 90S4
0.23	39200	5991	190000	1.30	
0.26	34900	5358	190000	1.45	
0.29	31200	4817	190000	1.60	
0.32	28300	4370	190000	1.75	
0.26	35000	5355	150000	0.90	
0.29	31200	4788	150000	1.05	
0.34	28800	4079	150000	1.20	K 167 R97 ESQ 90S4
0.41	22200	3376	150000	1.45	
0.51	18000	2755	150000	1.80	
0.64	14600	2182	150000	2.2	
0.82	11300	1704	150000	2.8	K 167 R97 ESQ 90S4
0.99	9330	1408	150000	3.4	
1.1	8560	1296	150000	3.7	
0.40	22900	3516	109300	0.80	K 157 R97 ESQ 90S4
0.46	20100	3051	111100	0.90	KF 157 R97 ESQ 90S4
0.54	16900	2610	112700	1.05	KA 157 R97 ESQ 90S4
0.60	15100	2322	113500	1.20	KAF 157 R97 ESQ 90S4
0.84	11000	1659	115000	1.65	
1.0	8970	1385	115800	2.0	K 157 R97 ESQ 90S4
1.1	8030	1229	115800	2.2	KF 157 R97 ESQ 90S4
1.3	7150	1093	116000	2.5	KA 157 R97 ESQ 90S4
1.5	6160	942	116100	2.9	KAF 157 R97 ESQ 90S4
1.6	5550	854	116200	3.2	

n2 [1/мин]	M [Н*м]	i	Fr2 [N]	fs	Редуктор + РАМ
0.73	13100	1926	79100	1.00	
0.80	11900	1757	79800	1.10	
0.91	10400	1541	80500	1.25	
1.0	9100	1342	81100	1.45	
1.2	7960	1177	81500	1.65	K 127 R77 ESQ 90S4
1.4	6950	1025	81800	1.85	KF 127 R77 ESQ 90S4
1.6	6080	899	82000	2.1	KA 127 R77 ESQ 90S4
1.8	5270	790	82200	2.5	KAF 127 R77 ESQ 90S4
2.0	4740	704	82400	2.7	
2.3	4090	610	82500	3.2	
2.5	3690	549	82500	3.5	
2.9	3180	477	82600	4.1	
1.2	7920	1166	85000	1.00	
1.4	6920	1030	85000	1.15	
1.5	6050	904	85000	1.30	
1.8	5380	793	85000	1.50	K 107 R77 ESQ 90S4
2.0	4700	696	85000	1.70	KF 107 R77 ESQ 90S4
2.3	4120	615	85000	1.95	KA 107 R77 ESQ 90S4
2.7	3500	522	85000	2.3	KAF 107 R77 ESQ 90S4
3.0	3080	461	85000	2.6	
3.4	2720	408	85000	2.9	
3.8	2450	364	85000	3.3	
4.4	2140	318	85000	3.7	
1.9	5030	743	39900	0.85	
2.2	4420	652	40000	0.95	K 97 R57 ESQ 90S4
2.4	3910	573	40000	1.10	KF 97 R57 ESQ 90S4
2.8	3400	504	40000	1.25	KA 97 R57 ESQ 90S4
3.2	2940	437	40000	1.45	KAF 97 R57 ESQ 90S4
3.7	2590	382	40000	1.65	
4.1	2300	342	40000	1.85	
3.0	3220	474	26600	0.85	
3.3	2890	426	27000	0.95	
3.8	2520	373	27500	1.05	K 87 R57 ESQ 90S4
4.2	2230	330	27800	1.20	KF 87 R57 ESQ 90S4
4.8	1980	294	28100	1.35	KA 87 R57 ESQ 90S4
5.6	1700	250	28300	1.60	KAF 87 R57 ESQ 90S4
5.9	1600	236	28400	1.70	
7.0	1360	204	28800	2.0	
3.9	2720	176.05	40000	1.60	K 97 ESQ 100LB8
4.4	2370	153.21	40000	1.80	KF 97 ESQ 100LB8
4.8	2170	140.28	40000	2.0	KA 97 ESQ 100LB8
5.5	1910	123.93	40000	2.2	KAF 97 ESQ 100LB8
5.2	2010	176.05	40000	2.1	K 97 ESQ 90L6
6.0	1750	153.21	40000	2.5	KF 97 ESQ 90L6
6.6	1600	140.28	40000	2.7	KA 97 ESQ 90L6
7.4	1420	123.93	40000	3.0	KAF 97 ESQ 90L6
7.9	1320	176.05	40000	3.3	K 97 ESQ 90S4
9.1	1150	153.21	40000	3.7	KF 97 ESQ 90S4
10	1050	140.28	40000	4.1	KA 97 ESQ 90S4
5.3	1990	174.18	28100	1.35	K 87 ESQ 90L6
5.6	1880	164.34	28200	1.45	KF 87 ESQ 90L6
6.2	1680	147.32	28300	1.60	KA 87 ESQ 90L6
7.2	1450	126.91	28500	1.85	KAF 87 ESQ 90L6
8.0	1310	174.19	28600	2.1	K 87 ESQ 90S4
8.5	1230	164.34	28700	2.2	KF 87 ESQ 90S4
9.5	1110	147.32	28700	2.4	KA 87 ESQ 90S4
11	950	126.91	28800	2.8	KAF 87 ESQ 90S4
12	870	115.82	28800	3.1	
6.8	1540	135.28	15400	1.00	K 77 ESQ 90L6
7.2	1470	128.52	15900	1.05	KF 77 ESQ 90L6
8.1	1300	113.56	17000	1.20	KA 77 ESQ 90L6
9.5	1110	97.05	17900	1.40	KAF 77 ESQ 90L6
10	1020	135.28	18300	1.55	K 77 ESQ 90S4
11	960	128.52	18400	1.60	KF 77 ESQ 90S4
12	850	113.56	18800	1.80	KA 77 ESQ 90S4
					KAF 77 ESQ 90S4

Каталог конических мотор-редукторов

n2 [1/мин]	M [Н*м]	i	Fr2 [N]	fs	Редуктор + ПАМ
14	730	97.05	19200	2.1	K 77 ESQ 90S4
16	670	88.97	19300	2.3	KF 77 ESQ 90S4
18	585	78.07	19500	2.7	KA 77 ESQ 90S4
19	555	73.99	19800	2.8	KAF 77 ESQ 90S4
13	610	108.03	10400	1.00	K 67 ESQ 90S4
14	770	102.62	10700	1.05	KF 67 ESQ 90S4
16	675	90.04	11400	1.20	KA 67 ESQ 90S4
18	575	76.37	12000	1.45	KAF 67 ESQ 90S4
20	515	68.95	12300	1.60	
23	455	60.66	12800	1.80	K 67 ESQ 90S4
24	430	57.28	12700	1.90	KF 67 ESQ 90S4
29	365	48.77	12900	2.2	KA 67 ESQ 90S4
32	335	44.32	13000	2.5	KAF 67 ESQ 90S4
36	290	38.39	13000	2.8	
16	675	90.26	2410	0.90	
18	575	76.56	7840	1.05	
20	520	69.12	8280	1.15	
23	455	60.81	8630	1.30	K 57 ESQ 90S4
24	430	57.42	8750	1.40	KF 57 ESQ 90S4
29	365	48.89	9020	1.65	KA 57 ESQ 90S4
32	335	44.43	9160	1.80	KAF 57 ESQ 90S4
36	290	38.49	9330	2.1	
39	270	35.70	9400	2.2	
46	225	30.28	9540	2.6	
51	205	27.34	9510	2.9	
58	181	24.05	9220	3.3	
62	170	22.71	9090	3.5	
72	145	19.34	8720	4.0	
80	132	17.57	8510	4.2	
92	114	15.22	8180	4.7	K 57 ESQ 90S4
106	99	13.25	7880	5.1	KF 57 ESQ 90S4
117	90	11.92	7570	4.6	KA 57 ESQ 90S4
124	85	11.26	7450	4.9	KAF 57 ESQ 90S4
146	72	9.59	7120	5.6	
161	65	8.71	6930	6.0	
186	57	7.55	6650	6.4	
213	49	6.57	6380	7.0	
25	425	56.83	3310	0.95	K 47 ESQ 90S4
					KF 47 ESQ 90S4
29	365	48.95	6380	1.10	KA 47 ESQ 90S4
30	345	46.03	6610	1.15	KAF 47 ESQ 90S4
35	295	39.61	7090	1.35	
40	265	35.39	7090	1.50	K 47 ESQ 90S4
45	235	31.30	6960	1.70	KF 47 ESQ 90S4*
48	220	29.32	6890	1.80	KA 47 ESQ 90S4*
54	194	25.91	6730	2.1	KAF 47 ESQ 90S4*
64	164	21.81	6510	2.4	
72	147	19.58	6380	2.7	
47	225	29.96	3420	0.90	
56	188	24.99	3440	1.05	
60	175	23.96	3440	1.10	
69	152	20.19	3420	1.20	
82	129	17.15	3370	1.40	
91	115	15.31	3330	1.50	K 37 ESQ 90S4
107	98	13.08	3200	1.70	KF 37 ESQ 90S4
115	91	12.14	3220	1.75	KA 37 ESQ 90S4
133	79	10.49	3140	2.0	KAF 37 ESQ 90S4
157	67	8.91	3040	2.4	
176	60	7.96	2970	2.6	
206	51	6.80	2870	2.9	
220	48	6.37	2830	3.0	
261	40	5.36	2720	3.5	
1.5 кВт					
0.21	60700	6747	171100	0.80	
0.24	53700	5991	183600	0.95	
0.26	47900	5358	190000	1.05	K 187 R97 ESQ 90L4
0.29	42900	4817	190000	1.15	
0.32	38900	4370	190000	1.30	

n2 [1/мин]	M [Н*м]	i	Fr2 [N]	fs	Редуктор + ПАМ
0.39	33000	3609	190000	1.50	
0.46	27800	3062	190000	1.80	K 187 R97 ESQ 90L4
0.56	22800	2519	190000	2.2	
0.62	20400	2268	190000	2.5	
0.35	36700	4079	150000	0.85	
0.42	30400	3376	150000	1.05	K 167 R97 ESQ 90L4
0.51	24700	2755	150000	1.30	
0.65	19900	2182	150000	1.60	
0.83	15500	1704	150000	2.1	K 167 R97 ESQ 90L4
1.0	12800	1408	150000	2.5	
1.1	11800	1296	150000	2.7	
0.61	20700	2322	110700	1.85	K 157 R97 ESQ 90L4
					KF 157 R97 ESQ 90L4
					KA 157 R97 ESQ 90L4
					KAF 157 R97 ESQ 90L4
0.85	15100	1659	113500	1.20	
1.0	12300	1365	114600	1.45	
1.1	11100	1229	115000	1.65	K 157 R97 ESQ 90L4
1.3	9840	1093	115300	1.85	KF 157 R97 ESQ 90L4
1.5	8480	942	115700	2.1	KA 157 R97 ESQ 90L4
1.6	7650	854	115900	2.3	KAF 157 R97 ESQ 90L4
2.5	5050	567	116300	3.6	
2.8	4490	504	116400	4.0	
2.6	4820	536	82300	2.7	K 127 R87 ESQ 90L4
					KF 127 R87 ESQ 90L4
3.4	3770	418	82500	3.5	KA 127 R87 ESQ 90L4
					KAF 127 R87 ESQ 90L4
3.8	3330	367	82600	3.9	
0.80	16200	1757	73400	0.80	
0.91	14200	1541	77500	0.90	
1.0	12400	1342	79500	1.05	
1.2	10900	1177	80300	1.20	
1.4	9470	1025	80900	1.35	K 127 R77 ESQ 90L4
1.6	8300	899	81400	1.55	KF 127 R77 ESQ 90L4
1.8	7210	790	81700	1.80	KA 127 R77 ESQ 90L4
2.0	6480	704	81900	2.0	KAF 127 R77 ESQ 90L4
2.3	5590	610	82200	2.3	
2.6	5040	548	82300	2.6	
3.0	4360	477	82400	3.0	
3.4	3840	418	82500	3.4	
1.4	9460	1030	65000	0.85	
1.6	8280	904	65000	0.95	
1.8	7330	739	65000	1.10	
2.0	6420	696	65000	1.25	K 107 R77 ESQ 90L4
2.3	5640	615	65000	1.40	KF 107 R77 ESQ 90L4
2.7	4780	522	65000	1.65	KA 107 R77 ESQ 90L4
3.1	4210	461	65000	1.90	KAF 107 R77 ESQ 90L4
3.5	3720	408	65000	2.2	
3.9	3350	364	65000	2.4	
4.4	2920	318	65000	2.7	
2.5	5320	573	38500	0.80	
2.8	4650	504	40000	0.95	
3.2	4020	437	40000	1.05	K 97 R57 ESQ 90L4
3.7	3540	382	40000	1.20	KF 97 R57 ESQ 90L4
4.1	3140	342	40000	1.35	KA 97 R57 ESQ 90L4
4.6	2820	305	40000	1.50	KAF 97 R57 ESQ 90L4
5.5	2380	258	40000	1.80	
6.1	2140	232	40000	2.0	
7.1	1840	199	40000	2.3	
4.3	3040	330	26800	0.90	
4.8	2700	294	27300	1.00	K 87 R57 ESQ 90L4
5.6	2310	250	27700	1.15	KF 87 R57 ESQ 90L4
6.0	2180	236	27900	1.25	KA 87 R57 ESQ 90L4
7.0	1860	201	28200	1.45	KAF 87 R57 ESQ 90L4
7.7	1690	183	28300	1.60	
4.9	2940	143.47	65000	2.7	K 107 ESQ 112M8
					KF 107 ESQ 112M8
5.8	2490	121.46	65000	3.2	KA 107 ESQ 112M8
					KAF 107 ESQ 112M8
6.2	2300	112.41	65000	3.5	

n2 [1/мин]	M [H*М]	i	Fr2 [N]	fs	Редуктор + PAM
4.6	3140	153.21	40000	1.35	K 97 ESQ 112M8
5.0	2870	140.28	40000	1.50	KF 97 ESQ 112M8
5.7	2540	123.93	40000	1.70	KA 97 ESQ 112M8
5.2	2740	176.05	40000	1.55	K 97 ESQ 100L6
6.0	2390	153.21	40000	1.80	KF 97 ESQ 100L6
6.6	2180	140.26	40000	1.95	KA 97 ESQ 100L6
7.4	1930	123.93	40000	2.2	KAF 97 ESQ 100L6
8.0	1790	176.05	40000	2.4	K 97 ESQ 90L4
9.2	1560	153.21	40000	2.8	KF 97 ESQ 90L4
10	1430	140.28	40000	3.0	KA 97 ESQ 90L4
11	1260	123.93	40000	3.4	KAF 97 ESQ 90L4
6.2	2290	147.32	27800	1.20	K 87 ESQ 100L6
7.2	1980	126.91	28100	1.35	KF 87 ESQ 100L6
7.9	1800	115.82	28200	1.50	KA 87 ESQ 100L6
9.0	1600	102.71	28400	1.70	KAF 87 ESQ 100L6
8.1	1770	174.19	28300	1.55	
8.6	1670	164.34	28300	1.60	K 87 ESQ 90L4
9.6	1500	147.32	28500	1.80	KF 87 ESQ 90L4
11	1290	126.91	28800	2.1	KA 87 ESQ 90L4
12	1180	115.82	28700	2.3	KAF 87 ESQ 90L4
14	1040	102.71	28800	2.6	
16	880	86.34	28800	3.1	
8.1	1770	113.56	13600	0.90	K 77 ESQ 100L6
9.5	1510	97.05	15700	1.05	KF 77 ESQ 100L6
10	1390	88.97	16400	1.10	KA 77 ESQ 100L6
12	1220	78.07	17400	1.30	KAF 77 ESQ 100L6
10	1370	135.28	16500	1.15	K 77 ESQ 90L4
11	1310	128.52	16900	1.20	KF 77 ESQ 90L4
12	1150	113.56	17700	1.35	KA 77 ESQ 90L4
15	990	97.05	18400	1.55	KAF 77 ESQ 90L4
16	900	88.97	18700	1.70	
18	795	78.07	19000	1.95	
19	750	73.99	19100	2.1	K 77 ESQ 90L4
22	660	64.75	19400	2.4	KF 77 ESQ 90L4
24	595	58.34	19500	2.6	KA 77 ESQ 90L4
28	520	51.18	19700	3.0	KAF 77 ESQ 90L4
31	460	45.16	19800	3.4	
35	405	40.04	19800	3.8	
16	910	90.04	9370	0.90	
18	775	76.37	10700	1.05	K 67 ESQ 90L4
20	700	68.95	11300	1.15	KF 67 ESQ 90L4
23	615	60.66	11800	1.35	KA 67 ESQ 90L4
25	580	57.28	12000	1.40	KAF 67 ESQ 90L4
29	495	48.77	12400	1.65	
32	450	44.32	12600	1.80	
37	390	38.39	12800	2.0	K 67 ESQ 90L4
40	360	35.62	12900	2.3	KF 67 ESQ 90L4
47	305	30.22	13000	2.7	KA 67 ESQ 90L4
52	275	27.28	13000	3.0	KAF 67 ESQ 90L4
59	245	24.00	13000	3.3	
23	620	60.61	7480	0.95	K 57 ESQ 90L4
25	685	57.42	7770	1.05	KF 57 ESQ 90L4
29	495	48.89	8430	1.20	KA 57 ESQ 90L4
32	450	44.43	8650	1.35	KAF 57 ESQ 90L4
37	390	38.49	8920	1.55	
39	365	35.70	9040	1.65	K 57 ESQ 90L4
47	310	30.28	9190	1.95	KF 57 ESQ 90L4
51	280	27.34	9010	2.2	KA 57 ESQ 90L4
59	245	24.05	8750	2.5	KAF 57 ESQ 90L4
62	230	22.71	8670	2.6	
73	196	19.34	8360	2.9	
36	400	39.61	5890	1.00	K 47 ESQ 90L4
40	360	35.39	6360	1.10	KF 47 ESQ 90L4
45	320	31.30	6310	1.25	KA 47 ESQ 90L4
					KAF 47 ESQ 90L4

n2 [1/мин]	M [H*М]	i	Fr2 [N]	fs	Редуктор + PAM
48	300	29.32	6270	1.35	
54	265	25.91	6190	1.50	
65	220	21.81	6050	1.80	K 47 ESQ 90L4
72	199	19.58	5950	2.0	KF 47 ESQ 90L4
84	171	16.86	5800	2.2	KA 47 ESQ 90L4
89	161	15.86	5730	2.4	KAF 47 ESQ 90L4
103	139	13.65	5560	2.6	
116	124	12.19	5430	2.8	
120	120	11.17	5340	2.3	
60	235	23.36	2860	0.80	
70	205	20.19	2920	0.90	
82	174	17.15	2940	1.05	
92	156	15.31	2950	1.10	
108	133	13.08	2930	1.25	K 37 ESQ 90L4
116	123	12.14	2920	1.30	KF 37 ESQ 90L4
134	107	10.49	2880	1.50	KA 37 ESQ 90L4
158	91	8.91	2820	1.75	KAF 37 ESQ 90L4
177	81	7.96	2770	1.90	
207	69	6.80	2700	2.2	
221	65	6.37	2670	2.2	
263	55	5.36	2580	2.6	
2.2 кВт					
0.32	57900	4370	176200	0.85	
0.50	37000	2818	190000	1.35	K 187 R97 ESQ 100LA4
0.39	48800	3609	190000	1.00	
0.46	41300	3062	190000	1.20	
0.56	33800	2519	190000	1.50	
0.62	30400	2288	190000	1.65	K 187 R97 ESQ 100LA4
0.69	27400	2054	190000	1.80	
0.77	24200	1821	190000	2.1	
0.88	21400	1605	190000	2.3	
0.51	36600	2755	150000	0.85	
0.62	29800	2263	150000	1.05	K 167 R97 ESQ 100LA4
0.65	29500	2182	150000	1.10	
0.83	22900	1704	150000	1.40	
1.0	19000	1408	150000	1.70	K 167 R97 ESQ 100LA4
1.1	17400	1298	150000	1.85	
1.3	14700	1101	150000	2.2	
1.5	12600	944	150000	2.5	
0.85	22400	1659	109700	0.80	
1.0	18300	1385	112000	1.00	K 157 R97 ESQ 100LA4
1.1	16500	1229	112900	1.10	KF 157 R97 ESQ 100LA4
1.3	14600	1093	113700	1.25	KA 157 R97 ESQ 100LA4
1.5	12600	942	114500	1.45	KAF 157 R97 ESQ 100LA4
1.6	11400	854	114900	1.60	
1.9	9990	756	115300	1.80	
2.6	7180	536	81700	1.80	K 127 R87 ESQ 100LA4
3.0	6310	473	82000	2.1	KF 127 R87 ESQ 100LA4
3.4	5600	418	82200	2.3	KA 127 R87 ESQ 100LA4
3.8	4950	367	82300	2.6	KAF 127 R87 ESQ 100LA4
4.3	4440	330	82400	2.9	
1.4	14000	1025	78000	0.95	
1.6	12200	899	78600	1.05	K 127 R77 ESQ 100LA4
1.8	10700	790	80400	1.20	KF 127 R77 ESQ 100LA4
2.0	9580	704	80900	1.35	KA 127 R77 ESQ 100LA4
2.3	8280	610	81400	1.55	KAF 127 R77 ESQ 100LA4
2.6	7460	549	81600	1.75	
3.0	6460	477	81900	2.0	
3.4	5680	418	82100	2.3	
2.3	8340	615	65000	0.95	
2.7	7070	522	65000	1.15	K 107 R77 ESQ 100LA4
3.1	6230	461	65000	1.30	KF 107 R77 ESQ 100LA4
3.5	5520	408	65000	1.45	KA 107 R77 ESQ 100LA4
3.9	4940	364	65000	1.60	KAF 107 R77 ESQ 100LA4
4.4	4320	318	65000	1.85	
4.9	3890	286	65000	2.1	
5.6	3410	251	65000	2.3	

Каталог конических мотор-редукторов

n2 [1/мин]	M [Н*м]	i	Fr2 [N]	fs	Редуктор + ПАМ
3.7	5210	382	39700	0.80	
4.1	4640	342	40000	0.95	K 97 R57 ESQ 100LA4
4.6	4170	305	40000	1.05	KF 97 R57 ESQ 100LA4
5.5	3510	258	40000	1.20	KA 97 R57 ESQ 100LA4
6.1	3160	232	40000	1.35	KAF 97 R57 ESQ 100LA4
7.1	2710	199	40000	1.60	
4.9	4310	143.47	65000	1.85	K 107 ESQ 132S8
5.8	3650	121.46	65000	2.2	KF 107 ESQ 132S8
6.2	3370	112.41	65000	2.4	KA 107 ESQ 132S8
6.9	3020	100.75	65000	2.7	KAF 107 ESQ 132S8
6.1	3420	153.21	40000	1.25	K 97 ESQ 112M6
6.7	3140	140.28	40000	1.35	KF 97 ESQ 112M6
7.6	2770	123.93	40000	1.55	KA 97 ESQ 112M6
8.9	2350	105.13	40000	1.85	KAF 97 ESQ 112M6
8.0	2820	176.05	40000	1.65	K 97 ESQ 100LA4
9.2	2280	153.21	40000	1.90	KF 97 ESQ 100LA4
10	2090	140.28	40000	2.1	KA 97 ESQ 100LA4
11	1850	123.93	40000	2.3	KAF 97 ESQ 100LA4
13	1570	105.13	40000	2.8	K 97 ESQ 100LA4 KF 97 ESQ 100LA4
15	1440	96.80	40000	3.0	KA 97 ESQ 100LA4 KAF 97 ESQ 100LA4
9.6	2200	147.32	27900	1.25	K 87 ESQ 100LA4
11	1890	126.91	28200	1.45	KF 87 ESQ 100LA4 KA 87 ESQ 100LA4
12	1730	115.82	28300	1.55	KAF 87 ESQ 100LA4
14	1530	102.71	28500	1.75	K 87 ESQ 100LA4
16	1290	86.34	28800	2.1	KF 87 ESQ 100LA4
18	1180	79.34	28700	2.3	KA 87 ESQ 100LA4
20	1050	70.46	28800	2.6	KAF 87 ESQ 100LA4
22	940	63.00	28800	2.9	
12	1690	113.56	14300	0.90	
15	1450	97.05	16100	1.05	K 77 ESQ 100LA4
16	1330	88.97	16800	1.15	KF 77 ESQ 100LA4
18	1160	78.07	17800	1.35	KA 77 ESQ 100LA4
19	1100	73.99	17900	1.40	KAF 77 ESQ 100LA4
22	960	64.75	18400	1.60	
24	870	58.34	18800	1.80	
28	765	51.18	19100	2.0	
31	675	45.16	19300	2.3	K 77 ESQ 100LA4
35	595	40.04	19500	2.6	KF 77 ESQ 100LA4
40	525	35.20	19700	3.0	KA 77 ESQ 100LA4
46	460	30.89	19800	3.4	KAF 77 ESQ 100LA4
48	435	29.27	19800	3.6	
55	380	25.62	19900	4.1	
23	900	60.66	9490	0.90	
25	850	57.28	10000	0.95	K 67 ESQ 100LA4
29	725	48.77	11100	1.15	KF 67 ESQ 100LA4
32	660	44.32	11500	1.25	KA 67 ESQ 100LA4
37	570	38.39	12100	1.40	KAF 67 ESQ 100LA4
40	530	35.62	12300	1.55	
47	450	30.22	12800	1.80	
52	405	27.28	12800	2.0	
59	360	24.00	13000	2.2	
62	340	22.66	13000	2.3	
73	285	19.30	13000	2.6	
80	260	17.54	13000	2.8	K 67 ESQ 100LA4
93	225	15.19	13000	3.1	KF 67 ESQ 100LA4
107	197	13.22	13000	3.4	KA 67 ESQ 100LA4
113	186	12.48	13000	2.8	KAF 67 ESQ 100LA4
133	158	10.63	13000	3.2	
146	144	9.66	13000	3.3	
169	125	8.37	13000	3.5	
194	109	7.28	12700	3.9	

n2 [1/мин]	M [Н*м]	i	Fr2 [N]	fs	Редуктор + ПАМ
32	660	44.43	5100	0.90	K 57 ESQ 100LA4
37	575	38.49	7850	1.05	KF 57 ESQ 100LA4
39	530	35.70	8080	1.15	KA 57 ESQ 100LA4
47	450	30.28	8250	1.35	KAF 57 ESQ 100LA4
52	405	27.34	8180	1.45	
59	360	24.05	8030	1.65	
62	340	22.71	7970	1.75	K 57 ESQ 100LA4
73	290	19.34	7760	2.0	KF 57 ESQ 100LA4
80	260	17.57	7630	2.1	KA 57 ESQ 100LA4
93	225	15.22	7430	2.4	KAF 57 ESQ 100LA4
106	197	13.25	7220	2.6	
118	178	11.92	6890	2.3	
125	168	11.28	6810	2.5	
54	385	25.91	5280	1.05	K 47 ESQ 100LA4
65	325	21.81	8260	1.25	KF 47 ESQ 100LA4 KA 47 ESQ 100LA4
72	290	19.58	5240	1.35	KAF 47 ESQ 100LA4
84	250	16.86	5190	1.50	
89	235	15.86	5160	1.60	K 47 ESQ 100LA4
103	205	123.65	5070	1.75	KF 47 ESQ 100LA4
116	182	12.19	4990	1.95	KA 47 ESQ 100LA4
120	175	11.77	4890	1.60	KAF 47 ESQ 100LA4
133	157	10.56	4810	1.80	
155	136	9.10	4690	2.1	
108	195	13.08	2370	0.85	
134	156	10.49	2430	1.00	K 37 ESQ 100LA4
158	133	8.91	2440	1.20	KF 37 ESQ 100LA4
177	119	7.96	2430	1.30	KA 37 ESQ 100LA4
207	101	6.80	2410	1.50	KAF 37 ESQ 100LA4
221	95	6.37	2400	1.55	
263	80	5.36	2350	1.75	
3 кВт					
0.50	51300	2818	187700	0.95	K 187 ESQ 100LB4
0.46	57100	3062	177600	0.90	
0.56	46800	2519	190000	1.05	
0.62	42100	2268	190000	1.20	
0.68	38000	2054	190000	1.30	K 187 R97 ESQ 100LB4
0.77	33600	1821	190000	1.50	
0.87	29700	1605	190000	1.70	
1.0	25600	1395	190000	1.95	
1.2	22100	1196	190000	2.3	
0.82	31700	1704	150000	1.00	
0.99	26200	1408	150000	1.20	
1.1	24100	1296	150000	1.35	
1.3	20300	1101	150000	1.55	K 167 R97 ESQ 100LB4
1.5	17500	944	150000	1.85	
1.7	15500	843	150000	2.1	
1.9	14000	757	150000	2.3	
1.1	22800	1229	109400	0.80	
1.3	20300	1093	111000	0.90	K 157 R97 ESQ 100LB4
1.5	17500	942	112400	1.05	KF 157 R97 ESQ 100LB4
1.6	15800	854	113200	1.15	KA 157 R97 ESQ 100LB4
1.9	13900	756	114000	1.30	KAF 157 R97 ESQ 100LB4
2.5	10500	567	115200	1.70	
2.8	9310	504	115500	1.95	
2.6	9940	536	80700	1.30	K 127 R87 ESQ 100LB4
3.0	8750	473	81200	1.50	KF 127 R87 ESQ 100LB4
3.3	7760	418	81500	1.70	KA 127 R87 ESQ 100LB4
3.8	6840	367	81800	1.90	KAF 127 R87 ESQ 100LB4
4.2	6140	330	82000	2.1	
4.9	5300	287	82200	2.5	
1.8	14800	790	76500	0.90	K 127 R77 ESQ 100LB4
2.0	13200	704	79100	1.00	KF 127 R77 ESQ 100LB4
2.3	11400	610	80000	1.15	KA 127 R77 ESQ 100LB4
2.5	10300	549	80800	1.25	KAF 127 R77 ESQ 100LB4
2.9	8920	477	81100	1.45	
3.3	7840	418	81500	1.65	

n2 [1/МИН]	M [H*М]	i	Fr2 [N]	fs	Редуктор + ПАМ
3.0	8610	461	65000	0.95	
3.4	7620	408	65000	1.05	
3.8	6820	364	65000	1.15	
4.4	5960	318	65000	1.35	K 107 R77 ESQ 100LB4
4.9	5370	286	65000	1.50	KF 107 R77 ESQ 100LB4
5.6	4700	251	65000	1.70	KA 107 R77 ESQ 100LB4
6.3	4150	222	65000	1.95	KAF 107 R77 ESQ 100LB4
7.1	3670	196	65000	2.2	
8.1	3250	174	65000	2.2	
9.1	2880	154	65000	2.5	
10	2610	140	65000	2.8	
5.4	4840	258	40000	0.90	K 97 R57 ESQ 100LB4
6.0	4360	232	40000	1.00	KF R57 ESQ 100LB4
7.0	3740	199	40000	1.15	KA R57 ESQ 100LB4
5.0	5710	143.47	65000	1.40	K107 ESQ 132M8
5.9	4830	121.46	65000	1.65	KF 107 ESQ 132M8
6.4	4470	112.41	65000	1.80	KA 107 ESQ 132M8
7.2	4010	100.75	65000	2.0	KAF 107 ESQ 132M8
7.9	3620	90.96	65000	2.2	
6.6	4370	143.47	65000	1.85	K107 ESQ 132S6
7.7	3700	121.46	65000	2.2	KF 107 ESQ 132S6
8.4	3430	112.41	65000	2.3	KA 107 ESQ 132S6
9.3	3070	100.75	65000	2.6	KAF 107 ESQ 132S6
9.8	2940	143.47	65000	2.7	K 107 ESQ 100LB4
					KF 107 ESQ 100LB4
					KA 107 ESQ 100LB4
12	2490	121.46	65000	3.2	KAF 107 ESQ 100LB4
7.6	3780	123.93	40000	1.15	K97 ESQ 132S6
8.9	3200	105.13	40000	1.35	KF 97 ESQ 132S6
9.7	2950	96.80	40000	1.45	KA 97 ESQ 132S6
11	2640	86.52	40000	1.65	KAF 97 ESQ 132S6
7.9	3600	176.05	40000	1.20	K 97 ESQ 100LB4
9.1	3140	153.21	40000	1.35	KF 97 ESQ 100LB4
10	2870	140.28	40000	1.50	KA 97 ESQ 100LB4
11	2540	123.93	40000	1.70	KAF 97 ESQ 100LB4
13	2150	105.13	40000	2.0	
14	1980	96.80	40000	2.2	K 97 ESQ 100LB4
16	1770	86.52	40000	2.4	KF 97 ESQ 100LB4
18	1590	77.89	40000	2.7	KA 97 ESQ 100LB4
20	1440	70.54	40000	3.0	KAF 97 ESQ 100LB4
22	1280	62.55	40000	3.4	
25	1160	56.55	40000	3.7	
9.5	3010	147.32	28900	0.90	K 87 ESQ 100LB4
11	2600	126.91	27400	1.05	KF 87 ESQ 100LB4
12	2370	115.82	27700	1.15	KA 87 ESQ 100LB4
14	2100	102.71	28000	1.30	KAF 87 ESQ 100LB4
16	1770	86.34	28300	1.55	
18	1620	79.34	28400	1.65	
20	1440	70.46	28500	1.85	K 87 ESQ 100LB4
22	1290	63.00	28600	2.1	KF 87 ESQ 100LB4
25	1160	56.64	28700	2.3	KA 87 ESQ 100LB4
28	1010	49.16	28800	2.7	KAF 87 ESQ 100LB4
32	900	44.02	28800	2.9	
38	745	36.52	28400	3.3	
16	1820	88.97	13100	0.85	
18	1600	78.07	15000	0.95	K 77 ESQ 100LB4
19	1510	73.99	15600	1.00	KF 77 ESQ 100LB4
22	1330	64.75	16800	1.15	KA 77 ESQ 100LB4
24	1190	58.34	17500	1.30	KAF 77 ESQ 100LB4
27	1050	51.18	18 100	1.50	
31	920	45.16	18600	1.70	K 77 ESQ 100LB4
35	820	40.04	18900	1.90	KF 77 ESQ 100LB4
40	720	35.20	19200	2.2	KA 77 ESQ 100LB4
45	630	30.89	19400	2.5	KAF 77 ESQ 100LB4

n2 [1/МИН]	M [H*М]	i	Fr2 [N]	fs	Редуктор + ПАМ
32	910	44.32	9450	0.90	
36	785	38.39	10600	1.00	K 67 ESQ 100LB4
39	730	35.62	11100	1.15	KF 67 ESQ 100LB4
46	620	30.22	11800	1.35	KA 67 ESQ 100LB4
51	560	27.28	12100	1.45	KAF 67 ESQ 100LB4
58	490	24.00	12500	1.65	
62	465	22.66	12600	1.70	
73	395	19.30	12800	1.95	
80	360	17.54	13000	2.1	K 67 ESQ 100LB4
92	310	15.19	13000	2.2	KF 67 ESQ 100LB4
106	270	13.22	13000	2.5	KA 67 ESQ 100LB4
112	255	12.48	13000	2.1	KAF 67 ESQ 100LB4
132	220	10.63	13000	2.3	
145	198	9.66	13000	2.4	
46	620	30.28	7180	0.95	K 57 ESQ 100LB4
51	560	27.34	7190	1.05	KF 57 ESQ 100LB4
58	490	24.05	7180	1.20	KA 57 ESQ 100LB4
62	465	22.71	7160	1.30	KAF 57 ESQ 100LB4
72	395	19.34	7080	1.45	
80	360	17.57	7020	1.55	
92	310	15.22	8890	1.70	K 57 ESQ 100LB4
106	270	13.25	6750	1.90	KF 57 ESQ 100LB4
117	245	19.92	6420	1.70	KA 57 ESQ 100LB4
124	230	11.26	6370	1.80	KAF 57 ESQ 100LB4
146	196	9.59	6200	2.1	
161	178	8.71	6090	2.2	
186	154	7.55	5920	2.4	
213	134	6.57	5750	2.6	
72	400	19.58	4430	1.00	K 47 ESQ 100LB4
83	345	18.86	4490	1.10	KF 47 ESQ 100LB4
88	325	15.86	4500	1.15	KA 47 ESQ 100LB4
103	280	13.65	4510	1.30	KAF 47 ESQ 100LB4
115	250	12.19	4490	1.40	
119	240	11.77	4370	1.15	K 47 ESQ 100LB4
133	215	10.56	4350	1.30	KF 47 ESQ 100LB4
154	186	9.10	4290	1.50	KA 47 ESQ 100LB4
164	175	8.56	4270	1.55	KAF 47 ESQ 100LB4
190	151	7.36	4190	1.65	
213	135	6.58	4120	1.80	
241	119	5.81	4030	1.95	
157	182	8.91	2000	0.90	K 37 ESQ 100LB4
176	163	7.96	2040	0.95	KF 37 ESQ 100LB4
206	139	6.80	2080	1.10	KA 37 ESQ 100LB4
220	130	6.37	2080	1.10	KAF 37 ESQ 100LB4
261	110	5.36	2090	1.30	
4 кВт					
1.7	20300	835	190000	2.5	
2.7	12600	520	190000	4.0	K 187 R107 ESQ 112M4
0.56	61900	2519	188800	0.80	
0.63	55600	2268	180200	0.90	
0.69	50300	2054	189400	1.00	
0.78	44500	1821	190000	1.10	
0.88	39300	1605	190000	1.25	K 187 R97 ESQ 112M4
1.0	34000	1395	190000	1.45	
1.2	29200	1196	190000	1.70	
1.4	25600	1046	190000	1.95	
1.5	23100	945	190000	2.2	
1.0	34600	1408	150000	0.90	
1.1	31900	1296	150000	1.00	
1.3	26900	1101	150000	1.20	
1.5	23100	944	150000	1.40	K 167 R97 ESQ 112M4
1.7	20500	843	150000	1.55	
1.9	18500	757	150000	1.75	
2.2	15400	632	150000	2.1	

Каталог конических мотор-редукторов

n2 [1/МИН]	M [Н*М]	i	Fr2 [N]	fs	Редуктор + ПАМ
1.7	20900	854	110600	0.85	K 157 R97 ESQ 112M4
1.9	18400	756	112000	1.00	KF 157 R97 ESQ 112M4
2.5	13800	567	114000	1.30	KA 157 R97 ESQ 112M4
2.8	12300	504	114600	1.45	KAF 157 R97 ESQ 112M4
3.3	10600	434	115100	1.70	
2.7	13100	536	79100	1.00	
3.0	11600	473	79900	1.10	K 127 R87 ESQ 112M4
3.4	10300	418	80600	1.25	KF 127 R87 ESQ 112M4
3.9	9040	367	81100	1.45	KA 127 R87 ESQ 112M4
4.3	8120	330	81400	1.60	KAF 127 R87 ESQ 112M4
5.0	7010	287	81800	1.85	
5.6	6200	253	82000	2.1	
2.3	15100	610	75800	0.85	K 127 R77 ESQ 112M4
2.6	13600	549	78800	0.95	KF 127 R77 ESQ 112M4
3.0	11800	477	79800	1.10	KA 127 R77 ESQ 112M4
3.4	10300	418	80500	1.25	KAF 127 R77 ESQ 112M4
3.9	8990	364	650000	0.90	
4.5	7860	318	650000	1.00	
5.0	7080	286	650000	1.15	K 107 R77 ESQ 112M4
5.7	6200	251	650000	1.30	KF 107 R77 ESQ 112M4
6.4	5470	222	650000	1.45	KA 107 R77 ESQ 112M4
7.2	4840	196	650000	1.65	KAF 107 R77 ESQ 112M4
8.2	4290	174	650000	1.70	
9.2	3800	154	650000	1.90	
10	3440	140	650000	2.1	
7.1	4930	199	40000	0.85	K 97 R57 ESQ 112M4 KF 97 R57 ESQ 112M4 KA 97 R57 ESQ 112M4 KAF 97 R57 ESQ 112M4
5.3	7220	132.14	81700	1.80	K 127 D132ML8
5.9	6500	122.48	81900	2.0	KF 127 D132ML8
6.5	5850	110.18	82100	2.2	KA 127 D132ML8
6.6	5810	146.07	82100	2.2	K 127 ESQ 132MA6
7.1	5420	136.14	82200	2.4	KF 127 ESQ 132MA6
7.8	4870	122.48	82300	2.7	KA 127 ESQ 132MA6
8.7	4380	110.18	82400	3.0	KAF 127 ESQ 132MA6
6.4	5960	112.41	65000	1.35	K 107 D132ML8
7.2	5340	100.75	65000	1.50	KF 107 D132ML8
7.9	4830	90.96	65000	1.65	KA 107 D132ML8
8.7	4380	82.61	65000	1.85	KAF 107 D132ML8
6.7	5710	143.47	65000	1.40	K 107 ESQ 132MA6
7.9	4830	121.46	65000	1.65	KF 107 ESQ 132MA6
8.5	4470	112.41	65000	1.80	KA 107 ESQ 132MA6
9.5	4010	100.75	65000	2.0	KAF 107 ESQ 132MA6
11	3620	90.96	65000	2.2	
9.9	3860	143.47	65000	2.1	
12	3270	121.46	65000	2.5	
13	3020	112.41	65000	2.7	K 107 ESQ 112M4
14	2710	100.75	65000	3.0	KF 107 ESQ 112M4
16	2450	90.96	65000	3.3	KA 107 ESQ 112M4
17	2220	82.61	65000	3.6	KAF 107 ESQ 112M4
19	1970	73.30	65000	4.1	
9.3	4120	153.21	40000	1.05	K 97 ESQ 112M4
10	3770	140.28	40000	1.15	KF 97 ESQ 112M4
11	3330	123.93	40000	1.30	KA 97 ESQ 112M4
14	2830	105.13	40000	1.50	KAF 97 ESQ 112M4
15	2600	96.80	40000	1.65	
16	2330	86.52	40000	1.85	K 97 ESQ 112M4
18	2100	77.89	40000	2.0	KF 97 ESQ 112M4
20	1900	70.54	40000	2.3	KA 97 ESQ 112M4
12	3120	115.82	26700	0.85	K 87 ESQ 112M4
14	2760	102.71	27200	1.00	KF 87 ESQ 112M4
16	2320	86.34	27700	1.15	KA 87 ESQ 112M4
18	2130	79.34	27900	1.25	KAF 87 ESQ 112M4

n2 [1/МИН]	M [Н*М]	i	Fr2 [N]	fs	Редуктор + ПАМ
20	1900	70.46	28200	1.40	
23	1690	63.00	28300	1.60	K 87 ESQ 112M4
25	1520	56.64	28500	1.75	KF 87 ESQ 112M4
29	1320	49.16	28600	2.0	KA 87 ESQ 112M4
32	1180	44.02	28300	2.2	KAF 87 ESQ 112M4
39	980	36.52	27300	2.5	
22	1740	64.75	13900	0.90	
24	1570	58.34	15200	1.00	K 77 ESQ 112M4
28	1380	51.18	16500	1.15	KF 77 ESQ 112M4
31	1210	45.16	17400	1.30	KA 77 ESQ 112M4
35	1080	40.04	18000	1.45	KAF 77 ESQ 112M4
37	1030	38.39	18200	1.45	
40	950	35.20	18500	1.65	
46	830	30.89	18900	1.85	K 77 ESQ 112M4
49	785	29.27	19000	1.95	KF 77 ESQ 112M4
55	690	25.62	19300	2.2	KA 77 ESQ 112M4
62	620	23.08	19500	2.5	KAF 77 ESQ 112M4
70	545	20.25	19800	2.8	
47	810	30.22	10400	1.00	K 67 ESQ 112M4
52	735	27.28	11000	1.10	KF 67 ESQ 112M4
59	645	24.00	11800	1.25	KA 67 ESQ 112M4
63	610	22.66	11800	1.30	KAF 67 ESQ 112M4
74	520	19.30	12300	1.45	
81	470	17.54	12500	1.55	
94	410	15.19	12800	1.70	K 67 ESQ 112M4
107	355	13.22	13000	1.90	KF 67 ESQ 112M4
114	335	12.48	13000	1.60	KA 67 ESQ 112M4
134	285	10.63	13000	1.75	KAF 67 ESQ 112M4
147	260	9.66	12900	1.85	
170	225	8.37	12500	1.95	
195	196	7.28	12100	2.1	
59	645	24.05	6120	0.95	
63	610	22.71	6160	1.00	
73	520	19.34	6220	1.10	
81	475	17.57	6230	1.15	
93	410	15.22	6210	1.30	K 57 ESQ 112M4
107	355	13.25	6150	1.45	KF 57 ESQ 112M4
119	320	11.92	5810	1.30	KA 57 ESQ 112M4
126	305	11.26	5790	1.35	KAF 57 ESQ 112M4
148	260	9.56	5700	1.55	
163	235	8.71	5640	1.65	
188	205	7.55	5530	1.80	
216	177	6.57	5400	1.95	
5.5 кВт					
0.79	61100	1821	170200	0.80	
0.89	53900	1605	183200	0.95	
1.0	46700	1395	190000	1.05	
1.2	40100	1196	190000	1.25	K 187 R97 ESQ 132S4
1.4	35100	1046	190000	1.45	
1.5	31700	945	190000	1.60	
1.9	24800	738	190000	2.0	
2.3	20800	621	190000	2.4	
1.3	36900	1101	150000	0.85	
1.5	31700	944	150000	1.00	
1.7	28200	843	150000	1.15	
1.9	25400	757	150000	1.25	
2.3	21200	632	150000	1.50	K 167 R97 ESQ 132S4
2.5	18700	561	150000	1.70	
3.0	16100	481	150000	2.0	
3.4	14100	423	150000	2.3	
2.2	22100	661	109900	0.80	
2.5	19000	567	117100	0.95	K 157 R97 ESQ 132S4
2.8	16900	504	112700	1.05	KF 157 R97 ESQ 132S4
3.3	14500	434	113800	1.25	KA 157 R97 ESQ 132S4
3.8	12700	379	114500	1.40	KAF 157 R97 ESQ 132S4
4.3	11100	333	115000	1.60	

n2 [1/мин]	M [H*М]	i	Fr2 [N]	fs	Редуктор + РАМ
3.4	14100	418	77800	0.90	
3.9	12400	367	79500	1.05	
4.3	11100	330	80200	1.15	
5.0	9620	287	80800	1.35	K 127 R87 ESQ 132S4
5.6	8510	253	81300	1.55	KF 127 R87 ESQ 132S4
6.7	7150	213	81700	1.80	KA 127 R87 ESQ 132S4
7.1	6740	200	81900	1.80	KAF 127 R87 ESQ 132S4
8.6	5560	166	82200	2.2	
9.8	4920	147	82300	2.4	
6.4	7490	222	65000	1.05	K 107 R77 ESQ 132S4
7.3	6640	196	65000	1.20	KF 107 R77 ESQ 132S4
8.2	5870	174	65000	1.25	KA 107 R77 ESQ 132S4
9.3	5200	154	65000	1.40	KAF 107 R77 ESQ 132S4
10	4720	140	65000	1.55	
4.7	11100	150.41	115000	1.60	K 157 ESQ 160MB8
5.8	9050	122.39	115500	2.0	KF 157 ESQ 160MB8
7.1	7410	100.22	115900	2.4	KA 157 ESQ 160MB8
7.8	6780	91.65	116000	2.7	KAF 157 ESQ 160MB8
5.2	10100	136.14	80700	1.30	K 127 ESQ 160MB8
5.8	9060	122.48	81100	1.45	KF 127 ESQ 160MB8
6.4	8150	110.18	81400	1.60	KA 127 ESQ 160MB8
7.9	6650	89.89	81900	1.95	KAF 127 ESQ 160MB8
7.1	7450	136.14	81600	1.75	K 127 ESQ 132MB6
7.8	6700	122.48	81900	1.95	KF 127 ESQ 132MB6
8.7	6030	110.18	82100	2.2	KA 127 ESQ 132MB6
11	4920	89.89	82300	2.6	KAF 127 ESQ 132MB6
8.5	6150	112.41	65000	1.30	K 107 ESQ 132MB6
9.5	5510	100.75	65000	1.45	KF 107 ESQ 132MB6
11	4980	90.96	65000	1.60	KA 107 ESQ 132MB6
12	4520	82.61	65000	1.75	KAF 107 ESQ 132MB6
10	5270	143.47	65000	1.50	
12	4460	121.46	65000	1.80	K 107 ESQ 132S4
13	4130	112.41	65000	1.95	KF 107 ESQ 132S4
14	3700	100.75	65000	2.2	KA 107 ESQ 132S4
16	3340	90.96	65000	2.4	KAF 107 ESQ 132S4
17	3030	82.61	65000	2.6	
12	4550	123.93	40000	0.95	K 97 ESQ 132S4
14	3860	105.13	40000	1.10	KF 97 ESQ 132S4
15	3560	96.80	40000	1.20	KA 97 ESQ 132S4
17	3180	86.52	40000	1.35	KAF 97 ESQ 132S4
18	2860	77.89	40000	1.50	
20	2590	70.54	40000	1.65	K 97 ESQ 132S4
23	2300	62.55	40000	1.85	KF 97 ESQ 132S4
25	2080	56.55	39700	2.1	KA 97 ESQ 132S4
30	1760	47.93	38800	2.4	KAF 97 ESQ 132S4
17	3170	86.34	25600	0.85	K 87 ESQ 132S4
18	2910	79.34	27000	0.95	KF 87 ESQ 132S4
20	2590	70.46	27400	1.05	KA 87 ESQ 132S4
23	2310	63.00	27500	1.15	KAF 87 ESQ 132S4
25	2080	56.64	27300	1.30	
29	1810	49.16	26900	1.50	K 87 ESQ 132S4
32	1620	44.02	26500	1.60	KF 87 ESQ 132S4
39	1340	36.52	25800	1.85	KA 87 ESQ 132S4
46	1150	31.39	25200	2.3	KAF 87 ESQ 132S4
51	1020	27.88	24700	2.5	
32	1660	45.16	14600	0.95	K 77 ESQ 132S4
36	1470	40.04	15900	1.05	KF 77 ESQ 132S4
46	1130	30.89	17800	1.35	KA 77 ESQ 132S4
49	1070	29.27	18000	1.45	KAF 77 ESQ 132S4
56	940	25.62	18500	1.65	
62	850	23.08	18800	1.85	
71	745	20.25	19100	2.0	K 77 ESQ 132S4
80	655	17.87	19400	2.2	KF 77 ESQ 132S4
90	580	15.84	19200	2.4	KA 77 ESQ 132S4
106	495	13.52	18600	2.7	KAF 77 ESQ 132S4
116	455	12.36	17900	2.2	
132	400	10.84	17400	2.5	

n2 [1/мин]	M [H*М]	i	Fr2 [N]	fs	Редуктор + РАМ
60	880	24.00	9720	0.90	
63	830	22.66	10200	0.95	K 67 ESQ 132S4
74	710	19.30	11200	1.05	KF 67 ESQ 132S4
82	645	17.54	11600	1.15	KA 67 ESQ 132S4
94	560	15.19	12100	1.25	KAF 67 ESQ 132S4
108	485	13.22	12500	1.40	
115	460	12.48	12600	1.15	
135	390	10.63	12400	1.30	K 67 ESQ 132S4
148	355	9.66	12200	1.35	KF 67 ESQ 132S4
171	305	8.37	11900	1.45	KA 67 ESQ 132S4
196	265	7.28	11600	1.55	KAF 67 ESQ 132S4
81	645	17.57	5080	0.85	
94	560	15.22	5210	0.95	
108	485	13.25	5280	1.05	K 57 ESQ 132S4
120	440	11.92	4920	0.95	KF 57 ESQ 132S4
127	415	11.26	4950	1.00	KA 57 ESQ 132S4
149	350	9.59	4990	1.15	KAF 57 ESQ 132S4
164	320	8.71	4990	1.20	
190	275	7.55	4960	1.30	
218	240	6.57	4910	1.45	
7.5 кВт					
1.7	38200	835	190000	1.30	
2.0	33300	729	190000	1.50	K 187 R107 ESQ 132M4
2.3	28400	622	190000	1.75	
1.2	55000	1196	181400	0.90	
1.4	48000	1046	190000	1.05	
1.5	43400	945	190000	1.15	K 187 R97 ESQ 132M4
1.9	33900	738	190000	1.45	
2.3	28500	621	190000	1.75	
2.7	24100	527	190000	2.1	
1.7	38700	843	150000	0.85	
1.9	34700	757	150000	0.90	
2.3	29000	632	150000	1.10	
2.5	25700	561	150000	1.25	K 167 R97 ESQ 132M4
3.0	22100	481	150000	1.45	
3.4	19400	423	150000	1.65	
3.9	16900	369	150000	1.90	
3.3	19900	434	111200	0.90	K 157 R97 ESQ 132M4
3.8	17400	379	112500	1.05	KF 157 R97 ESQ 132M4
4.3	15300	333	113500	1.20	KA 157 R97 ESQ 132M4
4.9	13300	291	114200	1.35	KAF 157 R97 ESQ 132M4
4.3	15200	330	75500	0.85	
5.0	13200	287	79100	1.00	K 127 R87 ESQ 132M4
5.6	11600	253	19900	1.10	KF 127 R87 ESQ 132M4
6.7	9790	213	80800	1.35	KA 127 R87 ESQ 132M4
7.1	9220	200	81000	1.30	KAF 127 R87 ESQ 132M4
8.6	7640	166	81600	1.55	
9.8	6740	147	81900	1.80	
4.4	16400	164.50	150000	1.95	
5.3	13400	134.99	150000	2.4	K 167 ESQ 160L8
5.8	12300	164.50	150000	2.6	
7.1	10100	134.99	150000	3.2	K 167 ESQ 160M6
6.4	11200	150.41	114900	1.60	K 157 ESQ 160M6
7.8	9130	122.39	115000	1.95	KF 157 ESQ 160M6
9.6	7480	100.22	115900	2.4	KA 157 ESQ 160M6
10	6840	91.65	116000	2.6	KAF 157 ESQ 160M6
12	5950	79.75	116200	3.0	
7.1	10200	136.14	80600	1.30	K 127 ESQ 160M6
7.8	9140	122.48	81000	1.40	KF 127 ESQ 160M6
8.7	8220	110.18	81400	1.60	KA 127 ESQ 160M6
11	6710	89.89	81900	1.95	KAF 127 ESQ 160M6
9.8	7320	146.07	81700	1.80	
11	6820	136.14	81800	1.90	K 127 ESQ 132M4
12	6130	122.48	82000	2.1	KF 127 ESQ 132M4
13	5520	110.18	82200	2.4	KA 127 ESQ 132M4
16	4500	89.89	82400	2.9	KAF 127 ESQ 132M4
17	4110	81.98	82500	3.2	
20	3500	70.95	82600	3.7	

Каталог конических мотор-редукторов

n2 [1/мин]	M [Н*м]	i	Fr2 [N]	fs	Редуктор + ПАМ
10	7180	143.47	65000	1.10	K 107 ESQ 132M4
12	6080	121.46	65000	1.30	KF 107 ESQ 132M4 KA 107 ESQ 132M4
13	5630	112.41	65000	1.40	KAF 107 ESQ 132M4
14	5050	100.75	65000	1.60	
16	4560	90.96	64200	1.75	
17	4140	82.61	63200	1.95	K 107 ESQ 132M4
20	3670	73.30	61900	2.2	KF 107 ESQ 132M4
22	3330	66.52	60900	2.4	KA 107 ESQ 132M4
25	2860	57.17	59100	2.8	KAF 107 ESQ 132M4
29	2500	49.90	57500	3.1	
34	2120	42.33	55500	3.5	
39	1850	37.00	53800	3.9	
15	4850	96.80	38300	0.90	K 97 ESQ 132M4
17	4330	86.52	38300	1.00	KF 97 ESQ 132M4
18	3900	77.89	38100	1.10	KA 97 ESQ 132M4
20	3530	70.54	37900	1.20	KAF 97 ESQ 132M4
23	3130	62.55	37500	1.35	
25	2830	56.55	37100	1.50	K 97 ESQ 132M4
30	2400	47.93	36400	1.80	KF 97 ESQ 132M4
34	2100	41.87	35600	2.0	KA 97 ESQ 132M4
37	1920	38.30	35100	2.2	KAF 97 ESQ 132M4
42	1710	34.23	34400	2.5	
23	3160	63.00	24100	0.85	K 87 ESQ 132M4
25	2840	56.64	24200	0.95	KF 87 ESQ 132M4
29	2460	49.16	24200	1.10	KA 87 ESQ 132M4
32	2200	44.02	24200	1.20	KAF 87 ESQ 132M4
39	1830	36.52	23900	1.35	
46	1570	31.39	23500	1.70	
51	1400	27.88	23200	1.85	
57	1250	24.92	22800	2.0	K 87 ESQ 132M4
64	1120	22.41	22500	2.0	KF 87 ESQ 132M4
74	970	19.45	21900	2.4	KA 87 ESQ 132M4
82	870	17.42	21500	2.5	KAF 87 ESQ 132M4
89	800	16.00	20600	2.2	
99	725	14.45	20700	2.9	
46	1550	30.89	15400	1.00	K 77 ESQ 132M4
49	1470	29.27	16000	1.05	KF 77 ESQ 132M4
56	1280	25.62	17000	1.20	KA 77 ESQ 132M4
62	1160	23.08	17700	1.35	KAF 77 ESQ 132M4
71	1010	20.25	18300	1.50	
80	890	17.87	18600	1.60	
90	795	15.84	18200	1.75	
106	675	13.52	17800	2.0	K 77 ESQ 132M4
116	620	12.36	17000	1.60	KF 77 ESQ 132M4
132	545	10.84	16700	1.80	KA 77 ESQ 132M4
150	480	9.56	16300	1.95	KAF 77 ESQ 132M4
169	425	8.48	15900	2.1	
198	365	7.24	15400	2.3	
9.2 кВт					
1.7	46700	835	190000	1.05	
2.0	40700	729	190000	1.25	
2.3	34700	622	190000	1.45	K 187 R107 D132L4
2.8	29100	520	190000	1.70	
3.2	25300	454	190000	1.95	
1.4	58600	1046	174800	0.85	
1.5	53000	945	184900	0.95	
2.0	41400	738	190000	1.20	K 187 R97 D132ML4
2.3	34800	621	190000	1.45	
2.7	29500	527	190000	1.70	
4.5	17800	318	150000	1.80	
5.2	15500	278	150000	2.1	
5.9	13600	244	150000	2.3	K 167 R107 D132ML4
6.8	11900	213	150000	2.7	
7.0	11500	206	150000	2.8	
2.3	35400	632	150000	0.90	
2.6	31300	561	150000	1.00	
3.0	27000	481	150000	1.20	K 167 R97 D132ML4
3.4	23700	423	150000	1.35	
3.9	20600	369	150000	1.55	

n2 [1/мин]	M [Н*м]	i	Fr2 [N]	fs	Редуктор + ПАМ
3.7	21400	385	110300	0.85	K 157 R107 ESQ 132M4
4.4	18100	325	112100	1.00	KF 157 R107 ESQ 132M4
4.8	16700	299	112800	1.10	KA 157 R107 ESQ 132M4
5.7	14100	253	113900	1.25	KAF 157 R107 ESQ 132M4
6.2	12800	230	114400	1.40	
3.8	21200	379	110400	0.85	K 157 R97 ESQ 132M4
4.3	18600	333	111900	0.95	KF 157 R97 ESQ 132M4
4.9	16300	291	113000	1.10	KA 157 R97 ESQ 132M4
					KAF 157 R97 ESQ 132M4
5.7	14200	253	77500	0.90	K 127 R87 ESQ 132M4
6.8	11900	213	79800	1.10	KF 127 R87 ESQ 132M4
7.2	11200	200	80100	1.05	KA 127 R87 ESQ 132M4
8.7	9320	166	81000	1.30	KAF 127 R87 ESQ 132M4
9.8	8230	147	81400	1.45	
11	8310	136.14	81300	1.55	K 127 D132ML4
12	7470	122.48	81600	1.75	KF 127 D132ML4
13	6720	110.18	8190	1.95	KA 127 D132ML4
16	5480	89.89	82200	2.4	KAF 127 D132ML4
18	5000	81.98	82300	2.6	
13	6860	112.41	62400	1.15	K 107 D132ML4
					KF 107 D132ML4
14	6150	100.75	61800	1.30	KA 107 D132ML4
					KAF 107 D132ML4
16	5550	90.96	61100	1.45	
17	5040	82.61	60400	1.60	
20	4470	73.30	59400	1.80	K 107 D132ML4
22	4060	66.52	58600	1.95	KF 107 D132ML4
25	3490	57.17	57100	2.3	KA 107 D132ML4
29	3040	49.90	55700	2.6	KAF 107 D132ML4
34	2580	42.33	54000	2.8	
18	4750	77.89	35100	0.90	K 97 D132ML4
20	4300	70.54	35100	1.00	KF 97 D132ML4
23	3820	62.55	35100	1.15	KA 97 D132ML4
25	3450	56.55	34900	1.25	KAF 97 D132ML4
30	2920	47.93	34400	1.45	
34	2550	41.87	34000	1.70	K 97 D132ML4
38	2340	38.30	33600	1.85	KF 97 D132ML4
42	2090	34.23	33100	2.1	KA 97 D132ML4
47	1880	30.82	32500	2.3	KAF 97 D132ML4
52	1700	27.91	32000	2.5	
58	1510	24.75	31300	2.8	
29	3000	49.16	22000	0.90	K 87 D132ML4
33	2630	44.02	22200	0.95	KF 87 D132ML4
39	2230	36.52	22200	1.10	KA 87 D132ML4
46	1910	31.39	22100	1.40	KAF 87 D132ML4
52	1700	27.88	21900	1.55	
58	1520	24.92	21700	1.65	
64	1370	22.41	21400	1.70	
74	1190	19.45	21000	1.95	K 87 D132ML4
83	1060	17.42	20700	2.1	KF 87 D132ML4
90	980	16.00	19700	1.85	KA 87 D132ML4
100	880	14.45	20000	2.4	KAF 87 D132ML4
115	765	12.56	19500	2.6	
129	680	11.17	18600	2.2	
144	610	10.00	18200	2.5	
62	1410	23.08	16300	1.10	K 77 D132ML4
71	1240	20.25	17300	1.20	KF 77 D132ML4
81	1090	17.87	17600	1.35	KA 77 D132ML4
91	970	15.84	17400	1.45	KAF 77 D132ML4
107	820	13.52	17000	1.60	
117	755	12.36	16300	1.35	K 77 D132ML4
133	660	10.84	16000	1.50	KF 77 D132ML4
151	585	9.56	15700	1.60	KA 77 D132ML4
170	515	8.48	15400	1.70	KAF 77 D132ML4
199	440	7.24	14900	1.85	

n2 [1/мин]	M [Н*м]	i	Fr2 [N]	fs	Редуктор + РАМ	
11 кВт						
1.7	55900	835	179700	0.90	K 187 R107 ESQ 160M4	
2.0	48800	729	190000	1.05		
2.3	41600	622	190000	1.20		
2.8	34800	520	190000	1.45		
3.2	30400	454	190000	1.65		
4.1	23800	355	190000	2.1		
2.0	49600	738	190000	1.00		K 187 R97 ESQ 160M4
2.3	41700	621	190000	1.20		
2.7	35300	527	190000	1.40		
4.5	21300	318	150000	1.50		
5.2	18600	278	150000	1.70		
5.9	16300	244	150000	1.95	K 167 R107 ESQ 160M4	
6.8	14200	213	150000	2.2		
7.0	13700	206	150000	2.3		
2.6	37500	561	150000	0.85		
3.0	32300	481	150000	1.00		K 167 R97 ESQ 160M4
3.4	28300	423	150000	1.15		
3.9	24700	369	150000	1.30		
4.3	22300	333	109700	0.80	K 157 R97 ESQ 160M4 KF 157 R97 ESQ 160M4 KA 157 R97 ESQ 160M4	
4.9	19500	291	111400	0.90	KAF 157 R97 ESQ 160M4	
6.8	14300	213	77400	0.90	K 127 R87 ESQ 160M4	
7.2	13500	200	78900	0.90	KF 127 R87 ESQ 160M4	
8.7	11200	166	80100	1.10	KA 127 R87 ESQ 160M4	
9.8	9850	147	80700	1.20	KAF 127 R87 ESQ 160M4	
5.3	19700	134.99	150000	1.60	K 167 ESQ 180L8	
6.6	16000	109.83	150000	2.0		
5.8	18000	164.50	150000	1.80	K 167 ESQ 160L6	
7.1	14800	134.99	150000	2.2		
8.8	12000	164.50	150000	2.7	K 167 ESQ 160M4	
11	9850	134.99	150000	3.2		
5.9	17900	122.39	112300	1.00	K 157 ESQ 180L8	
7.2	14600	100.22	113700	1.25	KF 157 ESQ 180L8	
7.9	13400	91.65	114200	1.35	KA 157 ESQ 180L8	
9.0	11600	79.75	114800	1.55	KAF 157 ESQ 180L8	
6.4	16500	150.41	112900	1.10	K 157 ESQ 160L6	
7.8	13400	122.39	114200	1.35		
9.6	11000	100.22	115000	1.65	KF 157 ESQ 160L6	
10	10000	91.65	115300	1.80	KA 157 ESQ 160L6	
12	8730	79.75	115600	2.1	KAF 157 ESQ 160L6	
9.6	11000	150.41	115000	1.65	K 157 ESQ 160M4	
12	8930	122.39	115600	2.0		
14	7310	100.22	115900	2.5	KA 157 ESQ 160M4	
16	6690	91.65	116000	2.7	KAF 157 ESQ 160M4	
11	9930	136.14	80700	1.30	K 127 ESQ 160M4	
12	8930	122.48	81100	1.45		
13	8040	110.18	81400	1.60	KF 127 ESQ 160M4	
16	6560	89.89	81900	2.0	KA 127 ESQ 160M4	
18	5980	81.98	82100	2.2	KAF 127 ESQ 160M4	
20	5180	70.95	82300	2.5		
13	8200	112.41	58400	1.00	K 107 ESQ 160M4	
14	7350	100.75	58300	1.10		
16	6630	90.96	58000	1.20	KA 107 ESQ 160M4	
17	6030	82.61	57500	1.35	KAF 107 ESQ 160M4	
20	5350	73.30	56900	1.50	K 107 ESQ 160M4	
22	4850	66.52	56200	1.65		
25	4170	57.17	55100	1.90	KF 107 ESQ 160M4	
29	3640	49.90	54000	2.2	KA 107 ESQ 160M4	
34	3090	42.33	52500	2.4	KAF 107 ESQ 160M4	
39	2700	37.00	51200	2.7		
20	5150	70.54	32200	0.85	K 97 ESQ 160M4	
23	4560	62.55	32500	0.95		
25	4130	56.55	32500	1.05	KA 97 ESQ 160M4	
30	3500	47.93	32500	1.25	KAF 97 ESQ 160M4	

n2 [1/мин]	M [Н*м]	i	Fr2 [N]	fs	Редуктор + РАМ	
34	3050	41.87	32200	1.40	K 97 ESQ 160M4 KF 97 ESQ 160M4 KA 97 ESQ 160M4 KAF 97 ESQ 160M4	
38	2790	38.30	32000	1.55		
42	2500	34.23	31600	1.70		
47	2250	30.82	31300	1.90		
52	2040	27.91	30800	2.1		
58	1800	24.75	30300	2.4		
64	1630	22.37	29800	2.6		
33	3210	44.02	20000	0.80		K 87 ESQ 160M4 KF 87 ESQ 160M4 KA 87 ESQ 160M4 KAF 87 ESQ 160M4
39	2860	36.52	20400	0.95		
46	2290	31.39	20600	1.20		
52	2030	27.88	20600	1.30		
58	1820	24.92	20500	1.40		
64	1630	22.41	20300	1.40	K 87 ESQ 160M4 KF 87 ESQ 160M4 KA 87 ESQ 160M4 KAF 87 ESQ 160M4	
74	1420	19.45	20100	1.60		
83	1270	17.42	19800	1.75		
90	1170	16.00	18800	1.55		
100	1050	14.45	19400	2.0		
115	920	12.56	18900	2.2		
129	810	11.17	18000	1.85		
144	730	10.07	17700	2.1		
174	605	8.29	17100	2.3		
200	525	7.21	16700	2.5		
62	1680	23.08	14400	0.90	K 77 ESQ 160M4 KF 77 ESQ 160M4 KA 77 ESQ 160M4 KAF 77 ESQ 160M4	
71	1480	20.25	15900	1.00		
81	1300	17.87	16600	1.10		
91	1160	15.84	16500	1.20		
107	990	13.52	16300	1.35		
117	900	12.36	15500	1.10		
133	790	10.84	15300	1.25		
151	700	9.56	15100	1.35		
170	620	8.48	14800	1.45		
199	530	7.24	14500	1.55		
15 кВт						
2.3	56100	622	179400	0.90	K 187 R107 ESQ 160L4	
2.8	47000	520	190000	1.05		
3.2	41000	454	190000	1.20		
4.1	32100	355	190000	1.55		
5.6	23600	261	190000	2.1		
4.6	28700	318	150000	1.10		K 167 R107 ESQ 160L4
5.3	25000	278	150000	1.30		
6.0	22000	244	150000	1.45		
6.8	19200	213	150000	1.65		
7.1	18500	206	150000	1.75		
8.1	16200	180	150000	1.95		
9.1	14400	160	150000	2.2		
6.3	20700	230	110700	0.85	K 157 R107 ESQ 160L4 KF 157 R107 ESQ 160L4 KA 157 R107 ESQ 160L4 KAF 157 R107 ESQ 160L4	
6.9	19200	213	116000	0.95		
7.8	16800	187	112800	1.05		
9.3	14200	157	113900	1.25		
12	11000	122	115000	1.65		
14	9630	107	115400	1.85	K 187 ESQ 180L6 K 167 ESQ 180L6 K 167 ESQ 160L4 K 167 ESQ 160L4	
5.4	26600	179.86	190000	1.90		
5.9	24400	165.21	190000	2.0		
7.2	19900	134.99	150000	1.60		
8.8	16200	109.83	150000	1.95		
8.9	16100	164.50	150000	2.0		
11	13200	134.99	150000	2.4		
7.9	18100	122.39	112200	1.00		K 157 ESQ 180L6 KF 157 ESQ 180L6 KA 157 ESQ 180L6 KAF 157 ESQ 180L6
9.7	14800	100.22	113700	1.20		
11	13500	91.65	114100	1.35		
12	11800	79.75	114800	1.55		
14	10400	70.38	115200	1.75		
9.7	14800	150.41	113700	1.20	K 157ESQ 160L4 KF 157 ESQ 160L4 KA 157 ESQ 160L4 KAF 157 ESQ 160L4	
12	12000	122.39	114700	1.50		
15	9830	100.22	114200	1.85		
16	8990	91.65	112500	2.0		
18	7820	79.75	109600	2.3		
11	13400	136.14	79000	0.95		K 127 ESQ 160L4 KF 127 ESQ 160L4 KA 127 ESQ 160L4 KAF 127 ESQ 160L4
12	12000	122.48	79700	1.10		
13	10800	110.18	80300	1.20		

Каталог конических мотор-редукторов

n2 [1/мин]	M [Н*м]	i	Fr2 [N]	fs	Редуктор + ПАМ
16	8820	89.89	81200	1.45	
18	8040	81.98	81400	1.60	K 127 ESQ 160L4
21	6960	70.95	81600	1.85	KF 127 ESQ 160L4
23	6140	62.60	80000	2.1	KA 127 ESQ 160L4
27	5300	54.07	78000	2.5	KAF 127 ESQ 160L4
31	4690	47.82	76200	2.8	
16	8920	90.96	50900	0.90	K 107 ESQ 160L4
18	8110	82.61	51100	1.00	KF 107 ESQ 160L4
20	7190	73.30	51200	1.10	KA 107 ESQ 160L4
22	6530	66.52	51000	1.25	KAF 107 ESQ 160L4
26	5610	57.17	50600	1.45	
29	4900	49.90	50000	1.60	K 107 ESQ 160L4
34	4150	42.33	49100	1.75	KF 107 ESQ 160L4
39	3630	37.00	48200	2.0	KA 107 ESQ 160L4
45	3210	32.69	47300	2.2	KAF 107 ESQ 160L4
47	3070	31.28	47000	2.2	
50	2840	29.00	46400	2.5	
30	4700	47.93	28100	0.90	K 97 ESQ 160L4
35	4110	41.87	28400	1.05	KF 97 ESQ 160L4
38	3760	38.30	28500	1.15	KA 97 ESQ 160L4
43	3360	34.23	28500	1.30	KAF 97 ESQ 160L4
47	3020	30.82	28400	1.40	
52	2740	27.91	28300	1.55	K 97 ESQ 160L4
59	2430	24.75	28000	1.75	KF 97 ESQ 160L4
65	2190	22.37	27700	1.95	KA 97 ESQ 160L4
77	1860	18.96	27200	2.3	KAF 97 ESQ 160L4
88	1620	16.56	26600	2.7	
47	3080	31.39	17300	0.90	
52	2730	27.88	17600	0.95	K 87 ESQ 160L4
59	2440	24.92	17800	1.00	KF 87 ESQ 160L4
65	2200	22.41	18000	1.05	KA 87 ESQ 160L4
75	1910	19.45	18000	1.20	KAF 87 ESQ 160L4
84	1710	17.42	18000	1.30	
91	1570	16.00	16800	1.15	
101	1420	14.45	17800	1.50	K 87 ESQ 160L4
116	1230	12.56	17600	1.60	KF 87 ESQ 160L4
131	1100	11.17	16600	1.35	KA 87 ESQ 160L4
146	980	10.00	16400	1.55	KAF 87 ESQ 160L4
176	810	8.29	16000	1.70	
202	705	7.21	15700	1.85	
18.5 кВт					
2.8	57800	520	176300	0.85	
3.2	50400	454	189200	1.00	
4.1	39500	355	190000	1.25	K 187 R107 ESQ 180M4
5.6	29000	261	190000	1.70	
6.6	24600	221	190000	2.0	
4.6	35300	318	150000	0.90	
5.3	30800	278	150000	1.05	
6.0	27100	244	150000	1.20	
6.9	23600	213	150000	1.35	
7.1	22800	206	150000	1.40	K 167 R107 ESQ 180M4
8.1	20000	180	150000	1.60	
9.2	17700	160	150000	1.80	
11	15000	135	150000	2.1	
12	13100	118	150000	2.4	
7.8	20700	187	110700	0.85	K 157 R107 ESQ 180M4
9.3	17400	157	112500	1.05	KF 157 R107 ESQ 180M4
12	13600	122	114100	1.35	KA 157 R107 ESQ 180M4
14	11900	107	112300	1.50	KAF 157 R107 ESQ 180M4
5.4	32800	179.86	190000	1.55	
5.9	30100	165.21	190000	1.65	K 187 ESQ 200LA6
6.7	26300	144.59	190000	1.90	
7.5	23600	129.69	190000	2.1	
8.1	21700	179.86	190000	2.3	
8.9	19900	165.21	190000	2.5	
10	17400	144.59	190000	2.9	K 187 ESQ 180M4
11	15600	129.69	190000	3.2	
11	16300	134.99	150000	1.95	
13	13200	109.83	150000	2.4	K 167 ESQ 180M4
17	10600	87.86	150000	3.0	

n2 [1/мин]	M [Н*м]	i	Fr2 [N]	fs	Редуктор + ПАМ
9.7	18300	100.22	112100	1.00	K 157 ESQ 200LA6
11	16700	91.65	112800	1.10	KF 157 ESQ 200LA6
12	14500	79.75	111500	1.25	KA 157 ESQ 200LA6
14	12800	70.38	109900	1.40	KAF 157 ESQ 200LA6
12	14800	122.39	111600	1.20	
15	12100	100.22	109100	1.50	
16	11100	91.65	107800	1.65	K 157 ESQ 180M4
18	9620	79.75	105600	1.85	KF 157 ESQ 180M4
21	8490	70.38	103400	2.1	KA 157 ESQ 180M4
24	7360	61.02	100700	2.5	KAF 157 ESQ 180M4
27	6550	54.29	98500	2.8	
31	5640	46.79	95500	3.2	
39	4580	38.02	91300	3.9	
13	13300	110.18	79000	1.00	K 127 ESQ 180M4
16	10800	89.89	79000	1.20	KF 127 ESQ 180M4
18	9890	81.98	78500	1.30	KA 127 ESQ 180M4
21	8560	70.95	77500	1.50	KAF 127 ESQ 180M4
23	7550	62.60	76400	1.70	
27	6520	54.07	74800	2.0	K 127 ESQ 180M4
31	5770	47.82	73400	2.2	KF 127 ESQ 180M4
36	4850	40.19	71300	2.7	KA 127 ESQ 180M4
40	4370	36.25	69900	3.0	KAF 127 ESQ 180M4
47	3780	31.37	68000	3.4	
53	3340	27.68	66200	3.9	
20	8840	73.30	46300	0.90	K 107 ESQ 180M4
22	8020	66.52	46600	1.00	KF 107 ESQ 180M4
26	6890	57.17	46800	1.15	KA 107 ESQ 180M4
29	6020	49.90	46700	1.30	KAF 107 ESQ 180M4
35	5100	42.33	46300	1.45	
40	4460	37.00	45700	1.60	
45	3940	32.69	45100	1.85	K 107 ESQ 180M4
47	3770	31.28	44900	1.80	KF 107 ESQ 180M4
51	3500	29.00	44400	2.1	KA 107 ESQ 180M4
56	3170	26.32	43800	2.3	KAF 107 ESQ 180M4
65	2730	22.62	42700	2.6	
74	2380	19.74	41700	3.0	
88	2020	16.75	40400	3.5	
35	5050	41.87	25100	0.85	K 97 ESQ 180M4
48	3720	30.82	26000	1.15	KF 97 ESQ 180M4
53	3360	27.91	26000	1.30	KA 97 ESQ 180M4
59	2980	24.75	26000	1.45	KAF 97 ESQ 180M4
65	2700	22.37	25900	1.60	K 97 ESQ 180M4
77	2290	18.96	25700	1.90	KF 97 ESQ 180M4
88	2000	16.56	25300	2.2	KA 97 ESQ 180M4
106	1670	13.85	24800	2.6	KAF 97 ESQ 180M4
122	1450	11.99	24300	2.7	
59	3000	24.92	15600	0.85	
65	2700	22.41	15900	0.85	
75	2340	19.45	16200	1.00	
84	2100	17.42	16400	1.05	K 87 ESQ 180M4
101	1740	14.45	16500	1.20	KF 87 ESQ 180M4
117	1510	12.56	16400	1.30	KA 87 ESQ 180M4
131	1350	11.17	15400	1.10	KAF 87 ESQ 180M4
147	1210	10.00	15300	1.25	
177	1000	8.29	15100	1.40	
203	870	7.21	14900	1.50	
22 кВт					
3.2	60000	454	172300	0.85	
4.1	47000	355	190000	1.05	
5.6	34500	261	190000	1.45	K 187 R107 ESQ 180L4
6.6	29300	221	190000	1.70	
7.6	25600	193	190000	1.95	
8.9	21600	163	190000	2.3	

n2 [1/МИН]	M [H*М]	i	Fr2 [N]	fs	Редуктор + ПАМ
5.3	36700	278	150000	0.85	
6.0	32200	244	150000	1.00	
6.9	28200	213	150000	1.15	
7.1	27200	206	150000	1.20	
8.1	23800	180	150000	1.35	K 167 R107 ESQ 180L4
9.2	21100	160	150000	1.50	
11	17900	135	150000	1.80	
12	15600	118	150000	2.0	
9.3	20800	157	109800	0.85	K 157 R107 ESQ 180L4
12	16200	122	108600	1.10	KF 157 R107 ESQ 180L4 KA 157 R107 ESQ 180L4
14	14100	107	107300	1.25	KAF 157 R107 ESQ 180L4
5.4	39000	179.86	190000	1.30	
5.9	35800	165.21	190000	1.40	
6.7	31300	144.59	190000	1.60	K 187 ESQ 200LB6
7.5	28100	129.69	190000	1.80	
8.6	24400	112.60	190000	2.0	
8.1	25800	179.86	190000	1.95	
8.9	23700	165.21	190000	2.1	
10	20700	144.59	190000	2.4	K 187 ESQ 180L4
11	18600	129.69	190000	2.7	
11	19400	134.99	150000	1.65	
13	15700	109.83	150000	2.0	K 167 ESQ 180L4
17	12600	87.86	150000	2.5	
19	11200	78.14	150000	2.9	
9.7	21700	100.22	105900	0.85	K 157 ESQ 200LB6
11	19900	91.65	105900	0.90	KF 157 ESQ 200LB6
12	17300	79.75	105500	1.05	KA 157 ESQ 200LB6
14	15200	70.38	104600	1.20	KAF 157 ESQ 200LB6
16	13200	61.02	103300	1.35	
12	17600	122.39	105500	1.05	
15	14400	100.22	104100	1.25	
16	13100	91.65	103200	1.35	K 157 ESQ 180L4
18	11400	79.75	101600	1.55	KF 157 ESQ 180L4
21	10100	70.38	99800	1.80	KA 157 ESQ180L4
24	8750	61.02	97700	2.1	KAF 157 ESQ180L4
27	7790	54.29	95800	2.3	
31	6710	46.79	93200	2.7	
39	5450	38.02	89400	3.3	
16	12900	89.89	73900	1.00	K 127 ESQ 180L4
18	11800	81.98	73800	1.10	KF 127 ESQ180L4
21	10200	70.95	73400	1.30	KA 127 ESQ180L4
23	8980	62.60	72800	1.45	KAF 127 ESQ180L4
27	7750	54.07	71700	1.70	
31	6860	47.82	70700	1.90	
36	5760	40.19	69000	2.3	K 127 ESQ 180L4
40	5200	36.25	67800	2.5	KF 127 ESQ180L4
47	4500	31.37	66200	2.9	KA 127 ESQ180L4
53	3970	27.68	64600	3.3	KAF 127 ESQ180L4
61	3430	23.91	62800	3.8	
69	3030	21.15	61200	4.3	
26	8200	57.17	43000	1.00	K 107 ESQ180L4
29	7160	49.90	43300	1.10	KF 107 ESQ180L4 KA 107 ESQ180L4
35	6070	42.33	43400	1.20	KAF 107 ESQ180L4
40	5310	37.00	43200	1.35	
45	4690	32.69	42900	1.55	
47	4490	31.28	42800	1.50	
51	4160	29.00	42500	1.75	
56	3770	26.32	42000	1.90	K 107 ESQ 180L4
65	3240	22.62	41200	2.2	KF 107 ESQ 180L4
74	2830	19.74	40400	2.5	KA 107 ESQ 180L4
88	2400	16.75	39300	2.9	KAF 107 ESQ 180L4
100	2100	14.64	38400	3.3	
109	1930	13.43	36800	2.2	
125	1680	11.73	35800	2.6	
147	1430	9.94	34800	2.9	

n2 [1/МИН]	M [H*М]	i	Fr2 [N]	fs	Редуктор + ПАМ
48	4420	30.82	23500	0.95	K 97 ESQ 180L4
53	4000	27.91	23800	1.05	KF 97 ESQ 180L4
59	3550	24.75	24100	1.20	KA 97 ESQ 180L4
65	3210	22.37	24200	1.35	KAF 97 ESQ 180L4
77	2720	18.96	24100	1.60	
88	2370	16.56	24000	1.80	K 97 ESQ 180L4
106	1990	13.85	23700	2.2	KF 97 ESQ 180L4
122	1720	11.99	23300	2.3	KA 97 ESQ 180L4
141	1490	10.41	21800	1.90	KAF 97 ESQ 180L4
168	1250	8.71	21300	2.1	
75	2790	19.45	14400	0.80	
84	2500	17.42	14800	0.90	
101	2070	14.45	15100	1.00	K 87 ESQ 180L4
117	1800	12.56	15300	1.10	KF 87 ESQ 180L4
131	1600	11.17	14200	0.95	KA 87 ESQ 180L4
147	1430	10.00	14200	1.05	KAF 87 ESQ 180L4
177	1190	8.29	14300	1.20	
203	1030	7.21	14200	1.25	
30 кВт					
5.6	47000	261	190000	1.05	
6.6	39800	221	190000	1.25	K 187 R107 ESQ 200L4
7.6	34800	193	190000	1.45	
9.0	29400	163	190000	1.70	
6.9	38300	213	150000	0.85	
7.1	37000	206	150000	0.85	
8.1	32400	180	150000	1.00	K 167 R107 ESQ 200L4
9.2	28700	160	150000	1.10	
11	24400	135	150000	1.30	
12	21300	118	150000	1.50	
8.2	35100	179.86	190000	1.45	
8.9	32200	165.21	190000	1.55	
10	28200	144.59	190000	1.75	
11	25300	129.69	190000	2.0	K 187 ESQ 200L4
13	21900	112.60	190000	2.3	
14	19900	102.16	190000	2.5	
17	17200	88.00	190000	2.9	
13	21400	109.83	150000	1.50	
17	17100	87.86	150000	1.85	
19	15200	78.14	150000	2.1	K 167 ESQ 200L4
22	13300	68.07	150000	2.4	
24	11800	60.74	150000	2.7	
15	19500	100.22	92700	0.90	
16	17900	91.65	92800	1.00	
18	15500	79.75	92400	1.15	K 157 ESQ 200L4
21	13700	70.38	91800	1.30	KF 157 ESQ 200L4
24	11900	61.02	90700	1.50	KA 157 ESQ 200L4
27	10600	54.29	89500	1.70	KAF 157 ESQ 200L4
31	9120	46.79	87800	1.95	
39	7410	38.02	85100	2.4	
47	6100	31.30	82200	3.0	
21	13800	70.95	64200	0.95	
23	12200	62.60	64600	1.05	
27	10500	54.07	64700	1.25	K 127 ESQ 200L4
31	9320	47.82	64400	1.40	KF 127 ESQ 200L4
37	7830	40.19	63700	1.65	KA 127 ESQ 200L4
41	7060	36.25	63100	1.85	KAF 127 ESQ 200L4
47	6110	31.37	62000	2.1	
53	5390	27.68	61000	2.4	
62	4660	23.91	59600	2.8	
35	8250	42.33	36100	0.90	K 107 ESQ 200L4
					KF 107 ESQ 200L4
40	7210	37.00	37600	1.00	KA 107 ESQ 200L4
					KAF 107 ESQ 200L4
47	6100	31.28	38000	1.10	

Каталог конических мотор-редукторов

n2 [1/МИН]	M [Н*М]	i	Fr2 [N]	fs	Редуктор + ПАМ
51	5650	29.00	38000	1.25	
56	5130	26.32	38000	1.40	
65	4410	22.62	37700	1.65	
74	3850	19.74	37400	1.85	K 107 ESQ 200L4
88	3260	16.75	36700	2.2	KF 107 ESQ 200L4
100	2850	14.64	36100	2.4	KA 107 ESQ 200L4
109	2620	13.43	34400	1.65	KAF 107 ESQ 200L4
125	2280	11.73	33800	1.90	
148	1940	9.94	33000	2.2	
169	1690	8.69	32200	2.4	
59	4820	24.75	19600	0.90	
66	4360	22.37	20100	1.00	
78	3690	18.96	20700	1.15	K 97 ESQ 200L4
89	3230	16.56	21000	1.35	KF 97 ESQ 200L4
106	2700	13.85	21200	1.60	KA 97 ESQ 200L4
123	2340	11.99	21100	1.65	KAF 97 ESQ 200L4
141	2030	10.41	19500	1.40	
169	1700	8.71	19400	1.55	
37 кВт					
5.6	58000	261	176000	0.85	
6.6	49200	221	190000	1.00	K 187 R107 ESQ 225S4
7.6	43000	193	190000	1.15	
9.0	36300	163	190000	1.40	
8.1	40000	180	150000	0.80	
9.2	35500	160	150000	0.90	K 167 R107 ESQ 225S4
11	30100	135	150000	1.05	
12	26300	118	150000	1.20	
8.2	43200	179.86	190000	1.15	
8.9	39700	165.21	190000	1.25	
10	34800	144.59	190000	1.45	
11	31200	129.69	190000	1.60	K 187 ESQ 225S4
13	27100	112.60	190000	1.85	
14	24600	102.16	190000	2.0	
17	21200	88.00	190000	2.4	
13	26400	109.83	150000	1.20	
17	21100	87.86	150000	1.50	
19	18800	78.14	150000	1.70	K 167 ESQ 225S4
22	16400	68.07	150000	1.95	
24	14600	60.74	150000	2.2	
28	12400	51.77	150000	2.6	
16	22000	91.65	83600	0.80	K 157 ESQ 225S4 KF 157 ESQ 225S4 KA 157 ESQ 225S4 KAF 157 ESQ 225S4
18	19200	79.75	84500	0.95	
21	16900	70.38	84800	1.05	
24	14700	61.02	84600	1.25	K 157 ESQ 225S4
27	13000	54.29	84100	1.40	KF 157 ESQ 225S4
31	11200	46.79	83200	1.60	KA 157 ESQ 225S4
39	9140	38.02	81300	1.95	KAF 157 ESQ 225S4
47	7520	31.30	79100	2.4	
23	15000	62.60	57500	0.85	K 127 ESQ 225S4
27	13000	54.07	58500	1.00	KF 127 ESQ 225S4
31	11500	47.82	59000	1.15	KA 127 ESQ 225S4
37	9660	40.19	59100	1.35	KAF 127 ESQ 225S4
41	8710	36.25	59000	1.50	
47	7540	31.37	58500	1.70	
53	6650	27.68	57800	1.95	
62	5740	23.91	56900	2.3	K 127 ESQ 225S4
70	5080	21.15	56000	2.6	KF 127 ESQ 225S4
83	4270	17.77	54500	3.0	KA 127 ESQ 225S4
102	3450	14.35	52500	3.5	KAF127 ESQ 225S4
115	3070	12.79	50200	2.8	
137	2580	10.74	48600	3.1	
169	2090	8.68	46600	3.5	

n2 [1/МИН]	M [Н*М]	i	Fr2 [N]	fs	Редуктор + ПАМ
40	8890	37.00	29000	0.80	
47	7520	31.28	33000	0.90	
51	6970	29.00	34200	1.05	
56	6320	26.32	34500	1.15	
65	5440	22.62	34700	1.30	K 107 ESQ 225S4
74	4740	19.74	34700	1.50	KF 107 ESQ 225S4
88	4020	16.75	34500	1.75	KA 107 ESQ 225S4
100	3520	14.64	34200	1.95	KAF107 ESQ 225S4
109	3230	13.43	32300	1.35	
125	2820	11.73	32000	1.55	
148	2390	9.94	31400	1.75	
169	2090	8.69	30900	1.95	
45 кВт					
6.6	59800	221	172600	0.85	
7.6	52300	193	186100	1.05	K 187 R107 ESQ 225M4
9.0	44200	163	190000	1.15	
11	36600	135	150000	0.85	K 167 R107 ESQ 225M4
12	32000	118	150000	1.00	
8.2	52600	179.86	185500	0.95	
8.9	48300	165.21	190000	1.05	
10	42300	144.59	190000	1.20	
11	37900	129.69	190000	1.30	K 187 ESQ 225M4
13	32900	112.60	190000	1.50	
14	29900	102.16	190000	1.65	
17	25700	88.00	190000	1.95	
20	21600	73.96	187700	2.3	
13	32100	109.83	150000	1.00	
17	25700	87.86	150000	1.25	
19	22800	78.14	150000	1.40	
22	19900	68.07	150000	1.60	K 167 ESQ 225M4
24	17800	60.74	149000	1.80	
28	15100	51.77	145600	2.1	
34	12500	42.89	140600	2.5	
21	20600	70.38	76800	0.85	
24	17800	61.02	77700	1.00	
27	15900	54.29	77900	1.15	
31	13700	46.79	77800	1.30	K 157 ESQ 225M4
39	11100	38.02	76900	1.60	KF 157 ESQ 225M4
47	9150	31.30	75500	1.95	KA 157 ESQ 225M4
53	8080	27.62	74300	2.2	KAF157 ESQ 225M4
61	7000	23.95	72800	2.6	
69	6230	21.31	71500	2.9	
80	5370	18.37	69700	3.3	
31	14000	47.82	52800	0.95	K 127 ESQ 225M4 KF 127 ESQ 225M4 KA 127 ESQ 225M4 KAF127 ESQ 225M4
37	11700	40.19	53900	1.10	
41	10600	36.25	54200	1.25	
47	9170	31.37	54400	1.40	
53	8090	27.68	54200	1.60	
62	6990	23.91	53800	1.85	K 127 ESQ 225M4
70	6180	21.15	53200	2.1	KF 127 ESQ 225M4
83	5190	17.77	52200	2.5	KA 127 ESQ 225M4
102	4190	14.35	50700	2.9	KAF127 ESQ 225M4
115	3740	12.79	48300	2.3	
137	3140	10.74	47000	2.5	
169	2540	8.68	45300	2.8	
51	8480	29.00	25600	0.85	K 107 ESQ 225M4
56	7690	26.32	28300	0.95	KF 107 ESQ 225M4
65	6610	22.62	31000	1.10	KA 107 ESQ 225M4
74	5770	19.74	31700	1.25	KAF107 ESQ 225M4
88	4890	16.75	31900	1.45	
100	4280	14.64	31900	1.60	K 107 ESQ 225M4
109	3930	13.43	29900	1.10	KF 107 ESQ 225M4
125	3430	11.73	29900	1.25	KA 107 ESQ 225M4
148	2910	9.94	29600	1.45	KAF107 ESQ 225M4
169	2540	8.69	29300	1.60	

n2 [1/мин]	M [H*М]	i	Fr2 [N]	fs	Редуктор + РАМ	
55 кВт						
10	51500	144.59	187400	0.95	K 187 ESQ 250M4	
11	46200	129.69	180000	1.10		
13	40100	112.60	188500	1.25		
14	36400	102.16	187100	1.35		
17	31300	88.00	184200	1.60		
20	26300	73.96	180200	1.90		
23	22800	64.04	176300	2.2		
17	31300	87.86	145300	1.00		K 167 ESQ 250M4
19	27800	78.14	144600	1.15		
22	24200	68.07	143300	1.30		
24	21600	60.74	141700	1.50		
28	18400	51.77	139100	1.75		
34	15300	42.89	135400	2.1		
40	13000	36.61	131900	2.5		
24	21700	61.02	69000	0.85	K 157 ESQ 250M4	
27	19300	54.29	70200	0.95		
32	16700	46.79	71200	1.10		
39	13500	38.02	71500	1.35		
47	11100	31.30	71000	1.60		
53	9840	27.62	70400	1.85		
62	8530	23.95	69400	2.1		
69	7590	21.31	68400	2.4		
80	6540	18.37	67000	2.8		
99	5310	14.92	64800	3.4		
117	4510	12.65	62900	3.8		
37	14300	40.19	47400	0.90	K 127 ESQ 250M4	
47	11200	31.37	49300	1.15	KF 127 ESQ 250M4	
53	8850	27.68	49700	1.30	KA 127 ESQ 250M4	
62	8510	23.91	49900	1.55	KAF 157 ESQ 250M4	
70	7530	21.15	49600	1.75	K 127 ESQ 250M4	
83	6330	17.77	49300	2.0		
103	5110	14.35	48300	2.4		
115	4550	12.79	45900	1.85		
137	3830	10.74	45000	2.1		
170	3090	8.68	43600	2.3		
75 кВт						
11	62800	129.69	164100	0.80		K 187 ESQ 280S4
13	45400	112.60	166100	0.90		
14	49400	102.16	166600	1.00		
17	42600	88.00	166600	1.15		
20	35800	73.96	165300	1.40		
23	31000	64.04	163400	1.60		
28	25800	53.36	160100	1.95		
33	22000	45.50	156700	2.3		
19	37800	78.14	128100	0.85	K 167 ESQ 280S4	
22	32900	68.07	127100	0.95		
24	29400	60.74	127300	1.10		
29	25100	51.77	126800	1.30		
35	20800	42.89	125200	1.55		
40	17700	36.61	123200	1.80		
46	15600	32.25	121300	2.0		
51	13900	28.77	119300	2.3		
60	11900	24.52	116300	2.7		
39	18400	38.02	60800	1.00		K 157 ESQ 280S4
47	15100	31.30	62200	1.20		
54	13400	27.62	62600	1.35		
62	11600	23.95	62600	1.55		
69	10300	21.31	62400	1.75		
81	8890	18.37	61800	2.0		
99	7220	14.92	60500	2.5		
117	6120	12.65	59300	2.8		
47	15200	31.37	39200	0.85	K 127 ESQ 280S4	
53	13400	27.68	40800	0.95		
62	11600	23.91	42200	1.10		
70	10200	21.15	42900	1.25		
83	8600	17.77	43500	1.50		
103	6940	14.35	43700	1.75		
116	6190	12.79	41100	1.40		
138	5200	10.74	41000	1.55		
171	4200	8.68	40400	1.70		

n2 [1/мин]	M [H*М]	i	Fr2 [N]	fs	Редуктор + РАМ	
90 кВт						
14	59300	102.16	151300	0.85	K 187 ESQ 280M4	
17	51100	88.00	153400	1.00		
20	42900	73.96	154200	1.15		
23	37200	64.04	153800	1.35		
28	31000	53.36	152200	1.60		
33	28400	45.50	149900	1.90		
35	24700	42.51	148700	2.0		
38	22400	38.57	146900	2.2		
22	39500	68.07	115100	0.80		K 167 ESQ 280M4
24	35300	60.74	116600	0.90		
29	30100	51.77	117600	1.05		
35	24900	42.89	117600	1.30		
40	21300	36.61	116700	1.50		
46	18700	32.25	115500	1.70		
51	16700	28.77	114200	1.90		
60	14200	24.52	111900	2.2		
73	11800	20.32	108800	2.7		
85	10100	17.34	106000	3.2		
39	22100	38.02	52700	0.80	K 157 ESQ 280M4	
47	18200	31.30	55500	1.00		
54	18000	27.62	56700	1.10		
62	13900	23.95	57500	1.30		
69	12400	21.31	57900	1.45		
81	10700	18.37	57900	1.70		
99	8670	14.92	57400	2.1		
117	7350	12.65	56600	2.3		
62	13900	23.91	36400	0.95		K 127 ESQ 280M4
70	12300	21.15	37800	1.05		
83	10300	17.77	39200	1.25		
103	8330	14.35	40200	1.45		
116	7420	12.79	37600	1.15		
138	6240	10.74	38000	1.30		
171	5040	8.68	38000	1.45		
110 кВт						
17	62300	88.00	136000	0.80	K 187 ESQ 315S4	
20	52300	73.96	139500	0.95		
23	45300	64.04	141000	1.10		
28	37700	53.36	141500	1.30		
33	32200	45.50	140800	1.55		
35	30100	42.51	140200	1.65		
39	27300	38.57	139100	1.85		
45	23500	33.23	137000	2.1		
53	19800	27.92	134000	2.5		
29	36600	51.77	105500	0.85		K 167 ESQ 315S4
35	30300	42.89	107500	1.05		
41	25900	36.61	108100	1.25		
46	22800	32.25	107900	1.40		
52	20400	28.77	107400	1.55		
61	17300	24.52	106100	1.85		
73	14400	20.32	104000	2.2		
86	12300	17.34	101800	2.6		
62	16900	23.95	50800	1.05	K 157 ESQ 315S4	
70	15100	21.31	51900	1.20		
81	13000	18.37	52700	1.40		
100	10600	14.92	53100	1.70		
117	8950	12.65	53000	1.90		
132 кВт						
20	62800	73.96	123300	0.80		K 187 ESQ 315M4
23	54400	64.04	127000	0.90		
28	45300	53.36	129800	1.10		
33	38600	45.50	130800	1.30		
35	36100	42.51	130900	1.40		
39	32700	38.57	130700	1.55		
45	28200	33.23	129800	1.75		
53	23700	27.92	127900	2.1		
61	20500	24.18	125900	2.3		
74	17100	20.15	122800	2.6		
86	14600	17.18	119700	2.8		

Каталог конических мотор-редукторов

n2 [1/МИН]	M [Н*М]	i	Fr2 [N]	fs	Редуктор + ПАМ
35	36400	42.89	96400	0.90	K 167 ESQ 315M4
41	31100	36.61	98600	1.05	
46	27400	32.25	99600	1.15	
52	24400	28.77	99900	1.30	
61	20800	24.52	99800	1.55	
73	17200	20.32	98700	1.85	
86	14700	17.34	97300	2.2	
62	20300	23.95	43400	0.90	
70	18100	21.31	45300	1.00	KF 157 ESQ 315M4
81	15600	18.37	47000	1.15	KA 157 ESQ 315M4
100	12700	14.92	48500	1.40	KAF157 ESQ 315M4
117	10700	12.65	49100	1.60	
160 кВт					
28	54900	53.36	114900	0.90	K 187 ESQ 315LA4
33	46800	45.50	118100	1.05	
45	34200	33.23	120500	1.45	
53	28700	27.92	120100	1.75	
61	24900	24.18	119100	1.90	
74	20700	20.15	117200	2.1	
86	17700	17.18	114900	2.3	
41	37700	36.61	86500	0.85	
61	25200	24.52	91700	1.25	
73	20900	20.32	82000	1.55	
86	17800	17.34	91600	1.80	
81	18900	18.37	39800	0.95	K 157 ESQ 315LA4
100	15400	14.92	42600	1.15	KF 157 ESQ 315LA4
117	13000	12.65	44100	1.30	KA 157 ESQ 315LA4

n2 [1/МИН]	M [Н*М]	i	Fr2 [N]	fs	Редуктор + ПАМ	
200 кВт						
33	58500	45.50	100000	0.85	K 187 ESQ 315LB4	
45	42700	33.23	107300	1.15		
53	35900	27.92	109000	1.40		
61	31100	24.18	109500	1.55		
74	25900	20.15	109100	1.70		
86	22100	17.18	108100	1.85		
61	31500	24.52	80100	1.00		K 167 ESQ 315LB4
73	26100	20.32	82400	1.20		
86	22300	17.34	83400	1.45		
100	19200	14.92	34200	0.95	K 157 ESQ 315LB4	
117	16300	12.65	36900	1.05	KF 157 ESQ 315LB4	
					KA 157 ESQ 315LB4	
					KAF157 ESQ 315LB4	

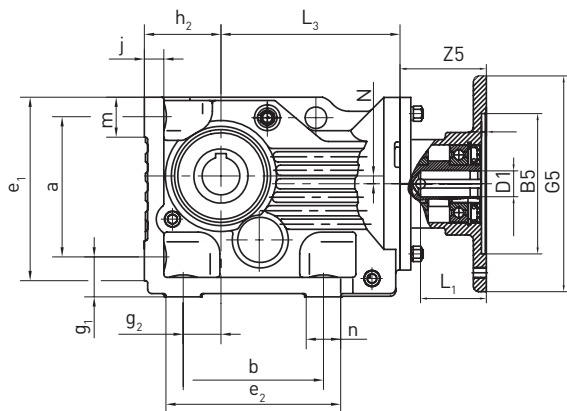

K37-K157

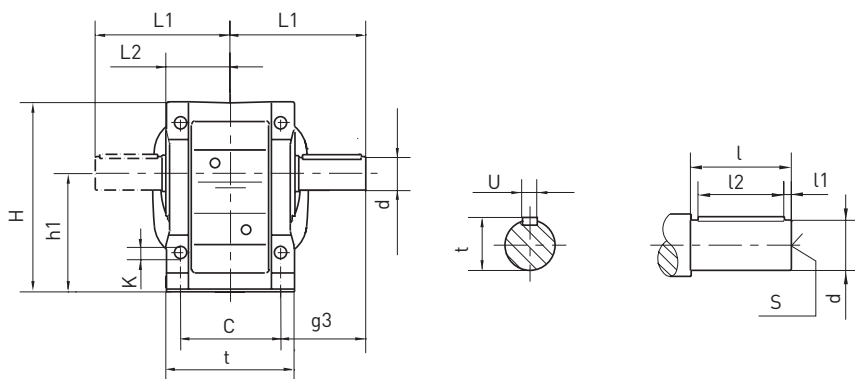

KA37B-KA157B

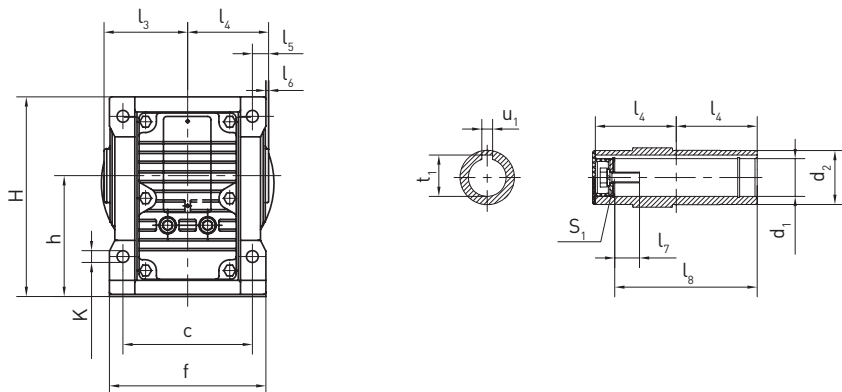

Каталог конических мотор-редукторов

Габарит	Размеры сплошного вала					Габарит	Размеры полого вала						
	d	l	l1 l2	s	t u		d1	d2	l3 l4	l5 l6	l7 l8	s1	t1 u1
K37	25k6	50	5 40	M10	28 8	KA37B	30H7	45	60 60	-	17 105	M10x25	33.3 8
K47	30k6	60	3.5 50	M10	33 8	KA47B	35H7	50	78 75	15 3	22 132	M12x30	38.3 10
K57	35k6	70	7 56	M12	38 10	KA57B	40H7	55	86 83	18 3	29 142	M16x40	43.3 12
K67	40k6	80	5 70	M16	43 12	KA67B	40H7	55	93 90	20 3.5	29 156	M16x40	43.3 12
K77	50k6	100	10 80	M16	53.5 14	KA77B	50H7	70	108 105	22.5 4	32 183	M16x45	53.8 14
K87	60m6	120	5 110	M20	64 18	KA87B	60H7	85	123 120	30 4	36 210	M20x50	64.4 18
K97	70m6	140	7.5 25	M20	74.5 20	KA97B	70H7	95	153 150	30 4	34 210	M20x50	74.9 20
K107	90m6	170	5 160	M24	95 25	KA107B	90H7	118	178 175	40 2.5	40 270	M24x60	95.4 25
K127	110m6	210	15 180	M24	115 28	KA127B	100H7	135	208 205	40 2.5	38 373	M24x60	106.4 28
K157	120m6	210	5 200	M24	127 32	KA157B	120H7	155	253 250	40	36 460	M24x60	127.4 32

Габарит	a b c	e1 e2 f	g1 g2 g3	h1 h2	J	k	m n	H	L1 L2	L3	N	Q
K37 KA37B	115 110 100	150 143 120	32 26 56.5	100 63 ^{-0.5}	16	11	37 38	165	110 60	139	8.5	120
K47 KA47B	130 130 120	170 162 145	37 35 77.5	112 71 ^{-0.5}	18	11	37 32	185	135 72	166	7.2	160
K57 KA57B	150 130 130	190 172 157	45 30 89.5	132 80 ^{-0.5}	21	13.5	43 40	217	153 80	173	13.1	160
K67 KA67B	160 120 140	203 170 170	45 30 102	140 90 ^{-0.5}	24	13.5	43 45	228	171 86.5	179	20	160
K77 KA77B	200 150 165	263 208 200	55 40 125	180 112 ^{-0.5}	27	17.5	55 55	288	206 101	202	31.3	200
K87 KA87B	233 180 180	305 260 230	70 55 151.5	212 132 ^{-0.5}	32	22	67 75	340	240 116	257	25.9	250
K97 KA97B	295 240 240	372 294 290	75 75 172.5	265 ⁻¹ 160 ^{-0.5}	36	26	82 60	417	291 146	277	32.3	300
K107 KA107B	360 280 270	448 380 340	95 95 215	315 ⁻¹ 200 ^{-0.5}	40	33	98 100	503	347 175	341	52	350
K127 KA127B	420 350 330	526 440 400	110 115 253	375 ⁻¹ 225 ^{-0.5}	45	39	111 100	592	418 203	390	53	450
K157 KA157B	500 380 420	634 480 500	130 140 247	450 ⁻¹ 280 ⁻¹	50	39	130 100	705	457 250	426	71.7	550

KA37...KA107

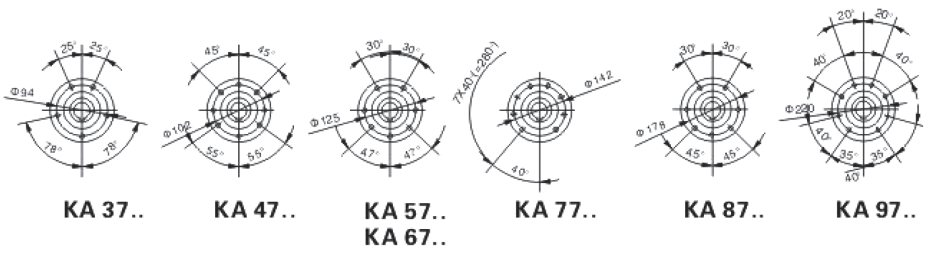
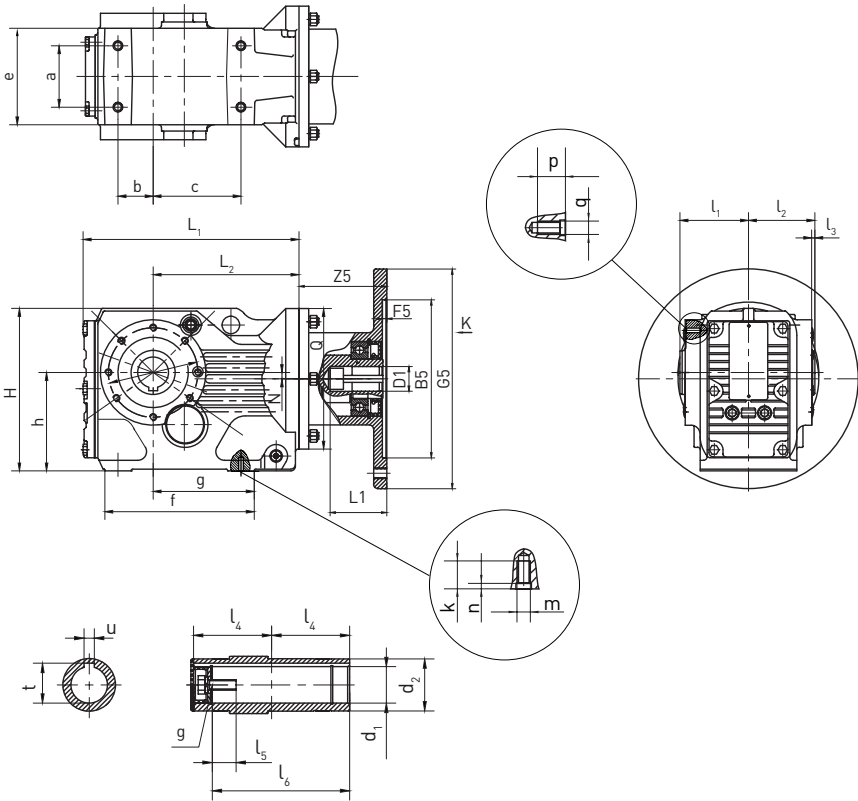

Каталог конических мотор-редукторов

Габарит	a b c	e f g	h	k m n	p q	d1 d2	l1 l2 l3	l4 l5 l6	s t u	g1 g2 g3	h1 h2 h3	d3 l7 l8	r s1	H L1 L2	N Q
KA37... K37/T...	60 35 82	100 147 97	100 ^{-0.5}	20 M10 4	12 M8	30 ^{H7} 45	63 60 2.5	60 17 105	M10 33.3 8	23.5 20 20	100 ^{-0.5} 10 140 ^{+0.2} -0.7	10.4 ^{+0.1} 31 36 ^{-0.3}	22.5 M10x25 60 ⁰	164 210 139	8.5 120
KA47... K47B...	70 70 100	110 170 115	112 ^{-0.5}	20 M10 4	12 M8	35 ^{H7} 50	78 75 3	75 22 132	M12 38.3 10	30 20 20	112 ^{-0.5} 12 160 ^{+0.2} -0.7	10.4 ^{+0.1} 31 36 ^{-0.3}	22.5 M10x30 55 ⁰	185 243 166	7.2 160
KA57... K57B...	88 47 105	122 182 120	132 ^{-0.5}	25 M12 5	20 M12	40 ^{H7} 55	86 83 3	86 29 142	M16 43.3 12	40 18 18	132 ^{-0.5} 13 192 ^{+0.2} -0.7	16.4 ^{+0.08} 54 60 ^{-0.3}	29 M12x35 55 ⁰	215 269 173	13.1 160
KA67... K67B...	88 42 110	130 182 125	140 ^{-0.5}	25 M12 5	20 M12	40 ^{H7} 55	94 90 3.5	90 29 156	M16 43.3 12	45 25 25	140 ^{-0.5} 13 200 ^{+0.2} -0.7	16.4 ^{+0.08} 54 60 ^{-0.3}	29 M12x35 55 ⁰	226 274 179	20 160
KA77... K77B...	102 48 122	154 204 139	180 ^{-0.5}	32 M16 6	20 M12	50 ^{H7} 70	108 105 4	105 32 186	M16 53.8 14	52.5 25 25	180 ^{-0.5} 14 250 ^{+0.2} -0.7	16.4 ^{+0.08} 54 60 ^{-0.3}	29 M16x40 60 ⁰	286 312 202	31.3 200
KA87... K87B...	118 65 160	170 280 190	212 ^{-0.5}	32 M16 6	26 M16	60 ^{H7} 85	123 120 4	120 36 210	M20 64.4 18	60 30 30	212 ^{-0.5} 16 300 ^{+0.2} -0.7	25 ^{+0.08} 72 80 ^{-0.3}	41 M16x45 60 ⁰	338 390 275	25.9 250
KA97... K97B...	160 83 165	226 298 190	262 ^{-0.5}	36 M20 6	26 M16	70 ^{H7} 95	153 150 4	150 34 270	M20 74.9 20	70 40 40	265 ^{-0.5} 17 350 ^{+0.2} -0.7	25 ^{+0.08} 90 100 ^{-0.3}	41 M20x50 50 ⁰	414 435 277	32.3 300
KA107... K107B...	190 100 190	366 370 230	315 ^{-0.5}	44 M24 6	-	90 ^{H7} 118	178 175 2.5	175 40 313	M24 95.4 25	74 45 45	315 ^{-0.5} 20 450 ^{+0.2} -0.7	25 ^{+0.08} 90 100 ^{-0.3}	41 M24x60 55 ⁰	500 537 341	52 350

K167..

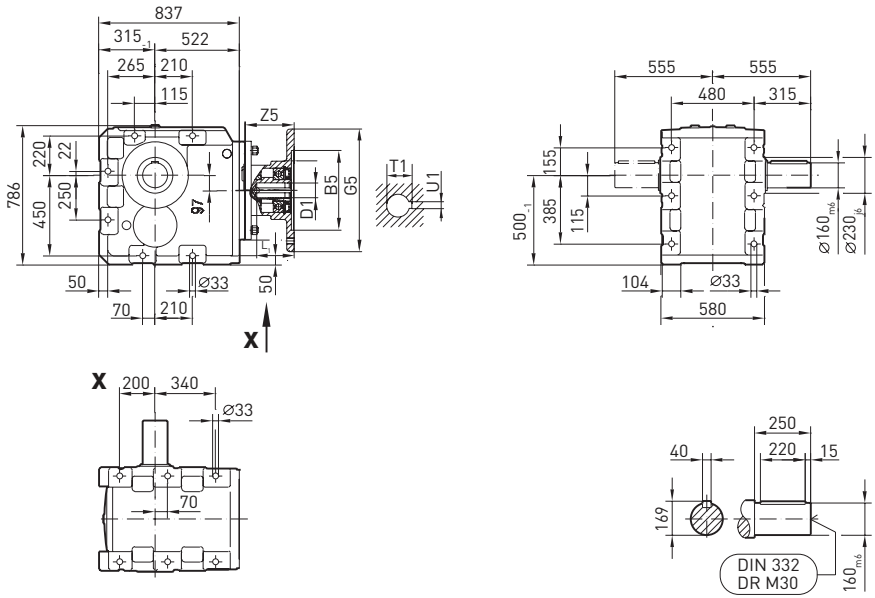

K187..

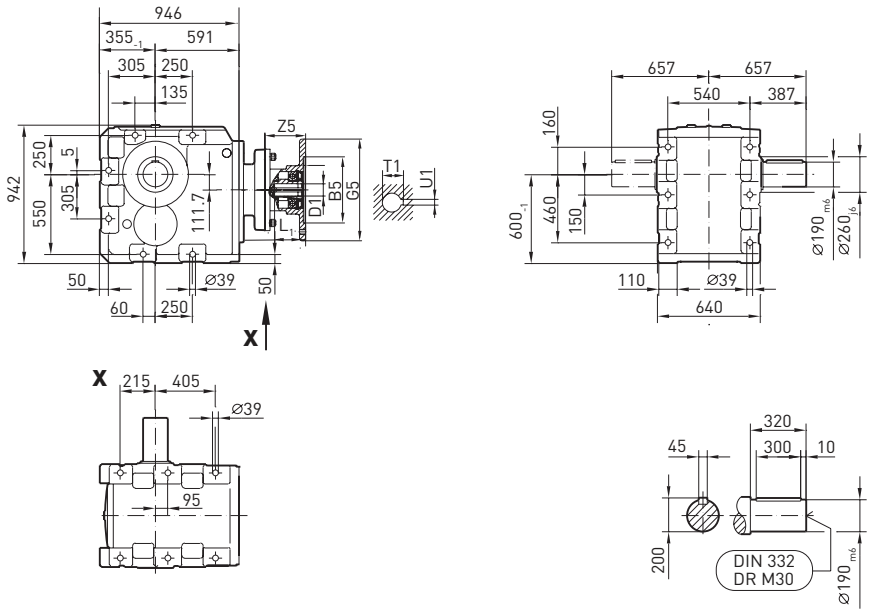

KF37..KF157..

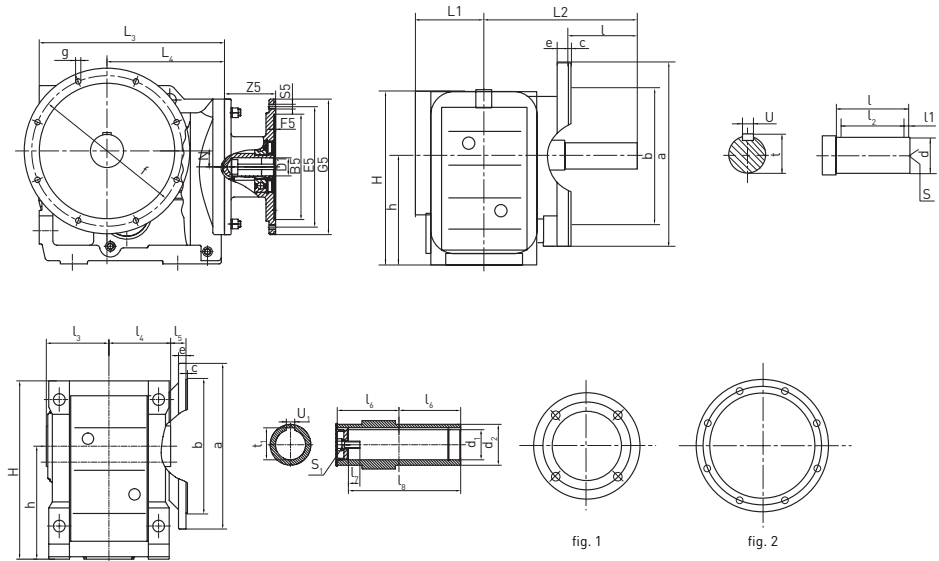

Габарит	a b	c e	f g h											H	L1 L2 L3	L4 N Q
				d l	l1 l2	s	t u	d1 d2	l3 l4 l5	l6 l7 l8	S1	t1 u1				
KF37... KAF37	Fig.1 160 110j6	3.5 10	130 9 100	25k6 50	5 40	M10	28 8	30H7 45	63 60 24	60 17 105	M10x25	33.3 8	164	57.5 13.4 210	139 8.5 120	
KF47... KAF47B...	Fig.1 200 130j6	3.5 10	165 11 112	30k6 60	3.5 50	M10	33 8	35H7 50	78 75 25	75 22 132	M12X30	38.3 10	185	72 160 243	166 7.2 160	
KF57... KAF57B...	Fig.1 250 180j6	4 15	215 13.5 132	35k6 70	7 56	M12	38 10	40H7 55	86 83 23.5	83 29 142	M16X40	43.3 12	215	80 177 269	173 13.1 160	
KF67... KAF67B...	Fig.1 250 180j6	4 15	215 13.5 140	40k6 80	5 70	M16	43 12	40H7 55	94 90 23	90 29 156	M16X40	43.3 12	226	86.5 19.3 274	179 20 160	
KF77... KAF77B...	Fig.1 300 230j6	4 15	265 13.5 180	50k6 100	80 10	M16	53.5 14	50H7 70	108 105 37	105 132 183	M16X45	53.8 14	286	101 242 312	202 31.3 200	
KF87... KAF87B...	Fig.1 350 250h6	5 18	300 17.5 212	60m6 120	5 110	M20	64 18	60H7 85	123 120 30	120 136 210	M20X50	64.4 18	338	138 270 390	157 25.9 250	
KF97... KAF97B...	Fig.2 450 350h6	5 22	400 17.5 265	70m6 140	7.5 125	M20	74.5 20	70H7 95	153 150 41.5	150 34 270	M20X50	74.9 20	414	171 332 435	277 32.3 300	
KF107... KAF107B...	Fig.2 450 350h6	5 22	400 17.5 315	90m6 170	5 160	M24	95 25	90H7 118	178 175 41	175 40 313	M24X60	95.4 25	500	175 386 537	341 52 350	
KF127... KAF127B...	Fig.2 550 450h6	5 25	500 17.5 375-1	110m6 210	15 180	M24	116 28	100H7 135	208 205 51	205 38 373	M24X60	106.4 28	592	203 466 615	390 53 450	
KF157... KAF157B...	Fig.2 660 550h6	6 28	600 22 450-1	120m6 210	5 200	M24	127 32	120H7 155	253 250 60	250 36 460	M24X60	127.4 32	705	253 520 706	705 71.7 550	

K..AM.. PAM (присоединительные размеры к двигателю)

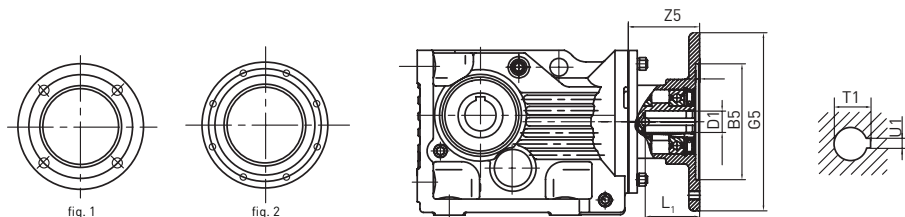

		Fig	B5	E5	F5	G2	G5	S5	Z5	D1	L1	T1	U1
K..37	AM63	1	95	115	3.5	120	140	M8	72	11	23	12.8	4
	AM71 ¹⁾		110	130			160			14	30	16.3	5
	AM80 ¹⁾		130	165	4.5		200	M10	106	19	40	21.8	6
	AM90 ¹⁾						24			50	27.3	8	
K..47 K...57 K...67	AM63	1	95	115	3.5	160	140	M8	66	11	23	12.8	4
	AM71		110	130			160			14	30	16.3	5
	AM80		130	165	4.5		200	M10	99	19	40	21.8	6
	AM90						24			50	27.3	8	
	AM100 ¹⁾		180	215	5		250	M12	134	28	60	31.3	8
	AM112 ¹⁾						28			60	31.3	8	
K..77	AM63	1	95	115	3.5	200	140	M8	60	11	23	12.8	4
	AM71		110	130			160			14	30	16.3	5
	AM80		130	165	4.5		200	M10	92	19	40	21.8	6
	AM90						24			50	27.3	8	
	AM100 ¹⁾		180	215	5		250	M12	126	28	60	31.3	8
	AM112 ¹⁾						28			60	31.3	8	
	AM132S ¹⁾		230	265	5		300	M12	179	38	80	41.3	10
	AM132M ¹⁾						38			80	41.3	10	
AM132ML ¹⁾	230	265	5	300	M12	174	38	80	41.3	10			
K..87	AM80	1	130	165	4.5	250	200	M10	87	19	40	21.8	6
	AM90						24			50	27.3	8	
	AM100		180	215	5		250	M12	121	28	60	31.3	8
	AM112						28			60	31.3	8	
	AM132S		230	265	5		300	M12	174	38	80	41.3	10
	AM132M						38			80	41.3	10	
	AM132ML		250	300	6		350	M16	232	42	110	45.3	6
	AM160 ¹⁾						48			51.8		8	
AM180 ¹⁾	250	300	6	350	M16	232	42	110	45.3	6			
K..97	AM100	1	180	215	5	300	250	M12	116	28	60	31.3	8
	AM112						28			60	31.3	8	
	AM132S		230	265	5		300	M12	169	38	80	41.3	10
	AM132M						38			80	41.3	10	
	AM132ML	250	300	6	350		M16	227	42	110	45.3	12	
	AM160				48				51.8		14		
	AM180	250	300	6	400		M16	268	55	110	59.3	16	
	AM200 ¹⁾				55				59.3		16		
AM225 ¹⁾	2	350	400	7	450		283	60	140	64.4	18		

К..AM.. PAM (присоединительные размеры к двигателю)

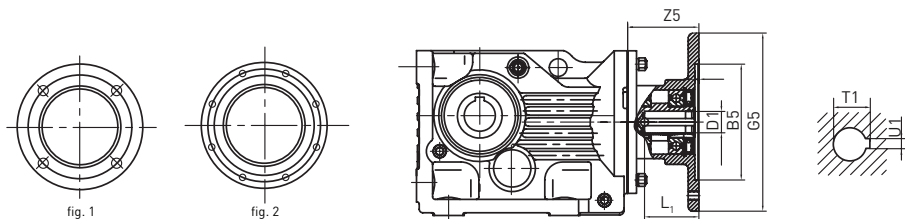
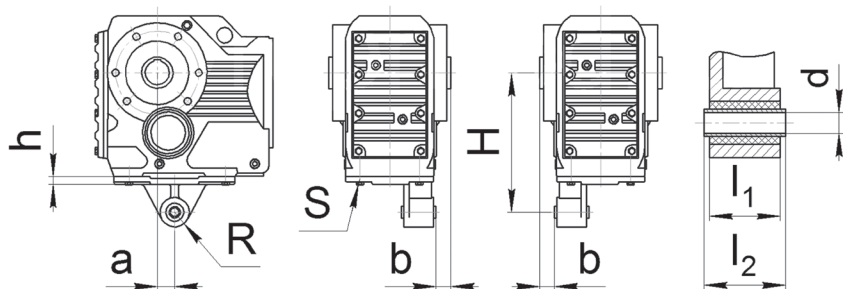
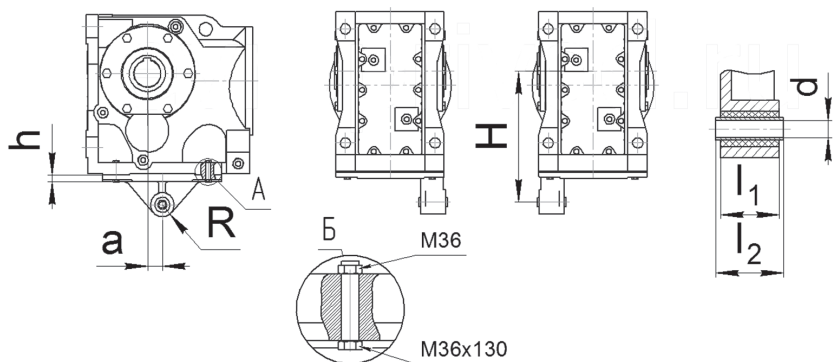

		Fig	B5	E5	F5	G2	G5	S5	Z5	D1	L1	T1	U1	
K..107	AM100	1	180	215	5	350	250	M12	110	28	60	31.3	8	
	AM112													
	AM132S													
	AM132M													
	AM132ML		230	265	6		350	300	M16	163	38	80	41.3	10
	AM160													
	AM180		250	300	7		350	400	M16	221	42	110	45.3	12
	AM200													
AM225	2	300	350	6	450	262	55	59.3	16					
K..127	AM132S	1	230	265	5	450	300	M12	148	38	80	41.3	10	
	AM132M													
	AM132ML													
	AM160													
	AM180	250	300	6	350		206	42	110	45.3	12			
	AM200	300	350	7	400		247	55		59.3	16			
	AM225	2	350	400	6		450	262	60	140	64.4	18		
	AM250		450	500	7		550	336	65		69.4			
AM280	75		79.9	20										
K..157	AM160		1	250	300	6	550	350	M16	198	42	110	45.3	12
	AM180													
K..167	AM200	300	350	7	400	239		55		59.3	16			
	K..187	AM225	350	400	6	450		254		60	140	64.4	18	
AM250		2	450	500	7	550		328	65	69.4				
AM280	75	79.9	20											

Размеры реактивной тяги КА 37...107



КА 127...157



Габарит редуктора	a	b	H	h	R	S	l_1	l_2	d
37	23,5	20	140	10	22,5	M10 x 25	31	36 _{-0,3}	10,4±0,1
47	30	20	160	12	22,5	M10 x 30	31	36 _{-0,3}	10,4±0,1
57	40	18	192	13	29	M12 x 35	54	60 _{-0,3}	16,4±0,08
67	45	25	200	13	29	M12 x 35	54	60 _{-0,3}	16,4±0,08
77	52,5	25	250	14	29	M16 x 40	54	60 _{-0,3}	16,4±0,08
87	60	30	300	16	41	M 16 x 45	72	80 _{-0,3}	25±0,08
97	70	40	350	17	41	M20 x 50	92	100 _{-0,3}	25±0,08
107	74	45	450	20	41	M24 x 60	92	100 _{-0,3}	25±0,08
127	60	0	550	45	70	M36 x 130	110	126 _{-0,3}	40±0,08
157	50	0	700	45	70	M36 x 130	110	126 _{-0,3}	40±0,08

1. Исполнение реактивной штанги

T1 (слева от входного вала), T2 (справа от входного вала)

T1

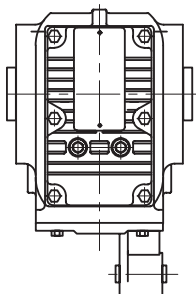

T2

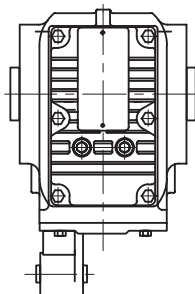

2. Исполнение выходного фланца

FA1 (слева от входного вала), FA2 (справа от входного вала)

FA1

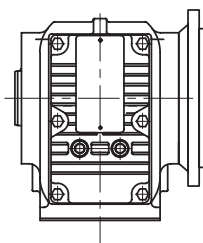

FA2

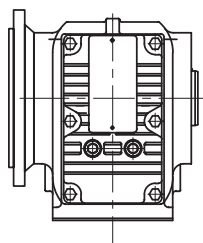

3. Исполнение выходного вала

SS1 (слева от входного вала), SS2 (справа от входного вала), DS (двухсторонний выходной вал)

SS1

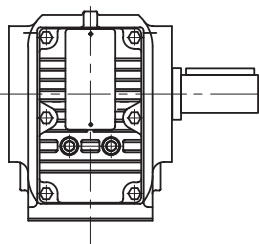

SS2

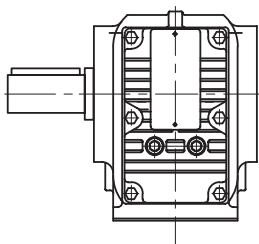

DS

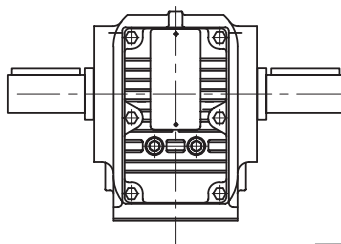

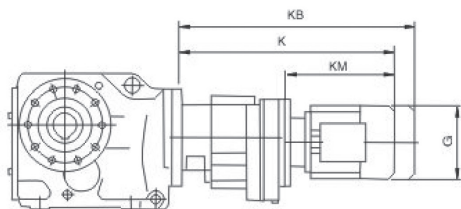

		G	K	KB	KM
K..37R17	D63..	155	368	425	193
	D71D	155	369	433	194
	D80..	155	419	483	244
K..47R17 K..67R37	D63..	155	400	457	235
	D71D	155	401	465	236
	D80..	155	451	515	286
K..57R37	D63..	155	410	457	235
	D71D	155	401	465	236
	D80..	155	451	515	286
	D90..	210	451	538	286
K..77R37	D63..	155	392	449	235
	D71D	155	393	457	236
	D80..	155	443	507	286
K..87R57	D90..	210	443	528	286
	D63..	155	445	502	229
	D71D	155	445	569	229
K..87R57	D80..	210	495	559	279
	D90..	210	495	580	279
	D100M	210	545	634	329
	D100L	210	565	650	349
K..97R57	D63..	155	440	497	229
	D71D	155	440	504	229
	D80..	210	490	554	279
	D90..	210	490	575	279
	D100M	210	540	625	329
	D100L	210	560	645	349
K..107R77	D112M	240	575	655	364
	D63..	155	470	527	223
	D71D	155	470	534	223
	D80..	155	520	584	273
	D90..	210	518	603	271
	D100M	210	568	653	321
	D100L	210	588	673	341
	D112M	240	602	682	355
	D132S	240	647	727	400
	D132M	285	699	811	452
D132ML	285	719	831	472	
D160M	330	749	861	512	

		G	K	KB	KM
K..127R77	D63..	155	45.5	512	223
	D71D	155	455	519	223
	D80..	155	505	569	273
	D90..	210	503	588	271
	D100M	210	553	638	321
	D100L	210	573	658	341
	D112M	240	587	657	355
	D132S	240	632	712	400
	D132M	285	684	796	452
	D132ML	285	704	816	472
K..127R87	D160M	330	734	846	502
	D90	210	547	632	267
	D100M	210	597	682	317
	DV100L	210	617	702	337
	D112M	240	630	710	350
	D132S	240	675	755	395
	D132M	285	727	839	447
	D132ML	285	747	859	467
	D160M	320	777	889	497
	DV160L	330	824	9.80	544
K..157R97 K167R97 KH167BR97 K187R97 KH187R97	D180..	aso	896	1052	616
	D80..	155	586	650	261
	D90..	210	586	671	261
	D100M	210	636	721	311
	D100L	210	658	741	331
	D112M	240	670	750	345
	D132S	240	715	795	339
	D132M	285	767	879	442
	D132ML	330	787	899	482
	D160M	330	817	929	492
K..157R107 K167R97 KH167BR97 K187R97 KH187R97	D160L	330	864	1020	539
	D180..	380	936	1092	611
	D200..	420	1024	1180	699
	D100M	210	687	772	305
	D100L	210	707	792	325
	D112M	240	721	801	339
	D132S	240	768	846	384
	D132M	285	818	930	436
	D132ML	285	838	9.50	456
	D160M	330	868	980	486
D160L	330	915	1071	533	
D180..	380	987	1143	605	
D200..	420	1075	1231	693	
D225..	470	1107	1263	725	